

Control and Performance Analysis of a Single-Stage Utility-Scale Grid-Connected PV System

¹ Mr. LUKKA BHANU GANESH, Assistant Professor, Department of EEE, bhanuganesh87@gmail.com

² BANOTH MUKESH, B.Tech, Department of EEE, mukeshbanoth2630@gmail.com

³ YEDULLA SOWMYA BINDHU, B.Tech, Department of EEE, sowmyabindhu72@gmail.com

⁴ KALLU PRIYANKA REDDY, B.Tech, Department of EEE, priyankakallu333@gmail.com

⁵ R. ANUSHMA REDDY, B.Tech, Department of EEE, anushma.reddy1@gmail.com

Vignan Institute of Technology & Science, Near Ramoji film city, Deshmuki Village.

ABSTRACT

For utility-scale photovoltaic (PV) frameworks, the control goals, for example, greatest power point following, synchronization with grid, current control, and harmonic reduction in yield current, are acknowledged in single stage for high efficiency and simple power converter geography. This paper considers a high-power three-phase single-stage PV framework, which is associated with a dissemination organization, with an adjusted control procedure, which incorporates pay for grid voltage plunge and reactive power infusion capacity. To manage the dc-interface voltage, a changed voltage controller utilizing criticism linearization plot with feed-forward PV current sign is introduced. The genuine and reactive powers are controlled by utilizing dq segments of the grid current. A little sign steadiness/eigenvalue investigation of a grid-associated PV framework with the total linearized model is performed to evaluate the power of the controller and the decoupling character of the grid-associated PV framework. The powerful presentation is assessed on a constant advanced test system.

Keywords: DC-link voltage control, feedback linearization(FBL), photovoltaic (PV) systems, reactive power control, smallsignal stability analysis, voltage dip.

I. INTRODUCTION

World is moving towards the greener sources of energy to make the planet pollution free and environment friendly. The major utilization of these sources with grid integration is the challenging task. It is therefore Distribution Generation particularly single phase rooftop Photo Voltaic system are major research area for grid integration, since these sources have huge opportunity of generation near load terminal. The rooftop application involving single phase Distribution Generation's fed with Photo Voltaic source can be not only utilized for household use but the excess energy can be transferred to the grid through proper control scheme and adequate hardware.

Photo Voltaic systems can generate high voltages. Safety is therefore very important in order to avoid accidents and damage of expensive components and equipment. For safety reasons, solar arrays are normally earthed, either by placing a matrix of metal in the ground under the array, or by using conventional earth rods. It is normally not necessary to protect solar array from direct lightning strikes, provided that their mounting structure is well earthed. However, inverters or other electronics controls connected to the array should be protected. Blocking

diodes are installed in solar arrays to prevent reverse current flows into the modules, which may damage the modules and cause energy losses. By-pass diodes are incorporated into modules to prevent damage of arrays when some cells or modules become shaded.

Photo Voltaic system requires regular maintenance to ensure proper operation and the full life of components. Some of the most important maintenance tasks are cleaning of modules front, Removal obstacles, tree branches, etc. Which cause shadowing of the modules, Battery charge check, if it remains very low the system should be re-designed, topping of battery electrolyte.

The rest of components of PV systems require little or no maintenance. The decentralized renewable energy production needs the continuous increase in the electrical energy with the clean environment. The increasing energy consumption may overload the distribution grid as well as power station and may cause the negative impact on power availability, security and quality.

The only solution to overcome this problem is integrating the utility grid with the renewable energy systems like solar energy, wind energy or hydro energy. As per the availability of renewable energy sources the grid can be connected to the renewable energy system. Because of abundant availability of solar energy recently the solar power generation systems are getting more attention, more efficient and more environment friendly as compared to the conventional power generation systems such as fossil fuel, coal or nuclear energy. Photovoltaic cells are devices that absorb sunlight and convert that solar energy into electrical energy.

When photons (sunlight) hit a solar cell, its energy frees electron-holes pairs. The electric field will send the free electron to the N side and hole to the P side. This causes further disruption of electrical neutrality, and if an external current path is provided, electrons will flow through the path to their original side (the P side) to unite with holes that the electric field sent there, doing work for us along the way. The electron flow provides the current, and the cell's electric field causes a voltage. With both current and voltage, we have power, which is the product of the two.

Three solar cell types are currently available: monocrystalline, polycrystalline, and thin film, discerned by material, efficiency, and composition.

By wiring solar cells in series, the voltage can be increased; or in parallel, the current. Solar cells are wired together to form a solar panel. Solar panels can be joined to create a solar array.

A battery is a source portable electric power. A storage battery is a reservoir, which may be used repeatedly for storing energy. Energy is charged and drained from the reservoir in the form of electricity, but it is stored as chemical energy. The most common storage battery is the lead-acid battery that is widely used in automobiles. They represent about 60% of all batteries sold worldwide and are usually more economical and have a high tolerance for abuse. Lead-acid batteries are inexpensive, relatively safe and easily recyclable, but have a low energy-to-weight ratio, which is a serious limitation when trying to build lightweight vehicles.

New battery technologies are constantly being explored that can offer better energy-to-weight ratios, lower costs and increased battery life. The nickel-metal-hydrate battery has received a great deal of attention as a near future solution. Nickel-metal-hydrate batteries offer about twice the energy capacity for the same weight as a current lead-acid battery. Another battery type with an even greater energy density is Lithium ion.

SYSTEM MODEL

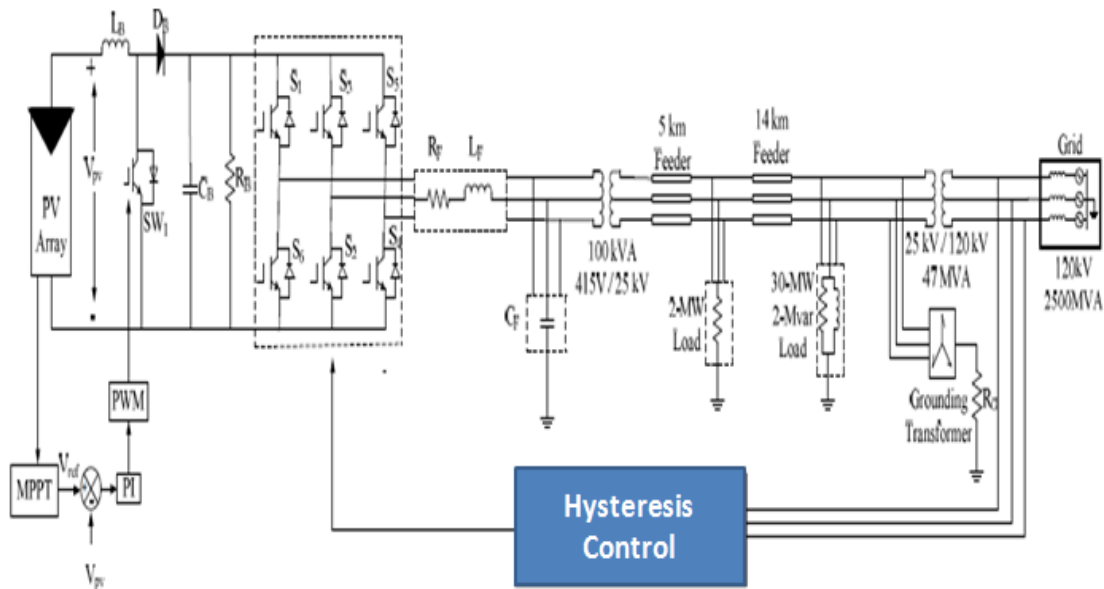

Fig. 1. System Configuration

There are two main system configurations – stand-alone and grid-connected. As its name implies, the stand-alone PV system operates independently of any other power supply and it usually supplies electricity to a dedicated load or loads. It may include a storage facility (e.g. battery bank) to allow electricity to be provided during the night or at times of poor sunlight levels. Stand-alone systems are also often referred to as autonomous systems since their operation is independent of other power sources. By contrast, the grid-connected PV system operates in parallel with the conventional electricity distribution system. It can be used to feed electricity into the grid distribution system or to power loads which can also be fed from the grid.

It is also possible to add one or more alternative power supplies (e.g. diesel generator, wind turbine) to the system to meet some of the load requirements. These systems are then known as ‘hybrid’ systems.

Hybrid systems can be used in both stand-alone and grid-connected applications but are more common in the former because, provided the power supplies have been chosen to be complementary, they allow reduction of the storage requirement without increased loss of load probability. Figures below illustrate the schematic diagrams of the three main system types.

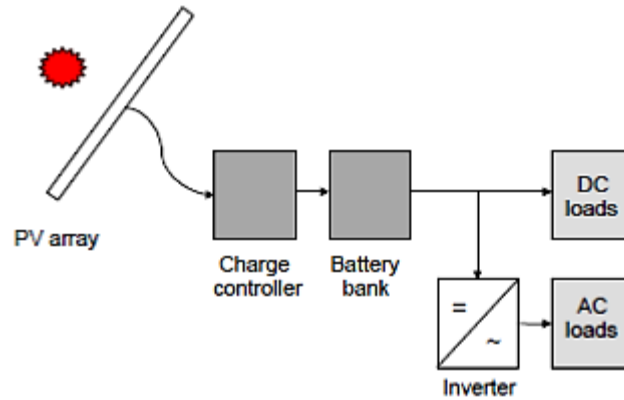

Fig. 2 Schematic Diagram of a Stand-alone Photovoltaic System.

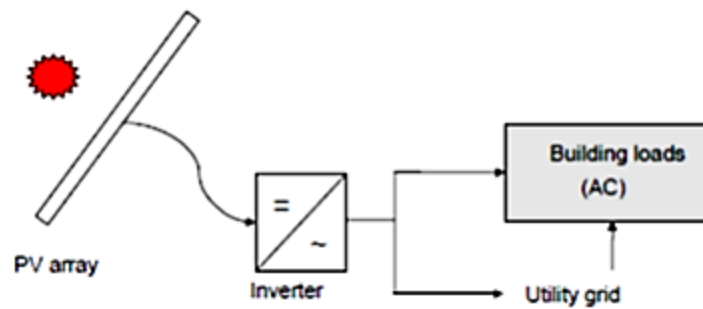

Fig. 3 Schematic Diagram of Grid-connected Photovoltaic System.

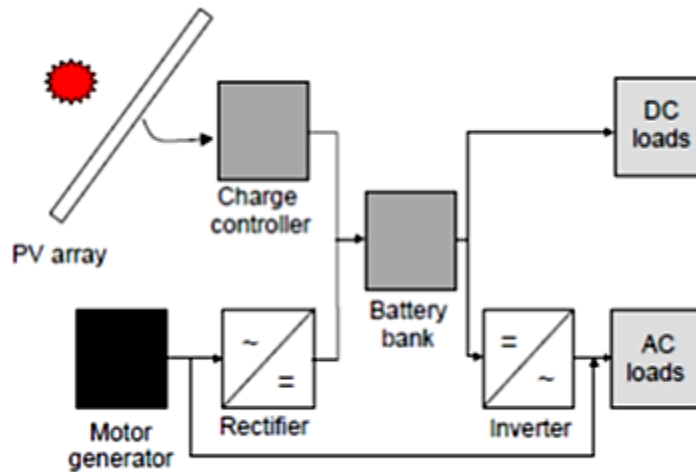

Fig. 4 Schematic Diagram of Hybrid System Incorporating a Photovoltaic Array and a Motor Generator (e.g. diesel or wind).

Generator characteristics and stability

A permanent magnet synchronous generator is a generator where the excitation field is provided by a permanent magnet instead of a coil. The term synchronous refers here to the fact that the rotor and magnetic field rotate with

the same speed, because the magnetic field is generated through a shaft mounted permanent magnet mechanism and current is induced into the stationary armature.

PROPOSED SCHEME

The Photo Voltaic systems are still very expensive because of higher manufacturing cost of the Photo Voltaic panels, but the energy that drives them the light from the sun is free, available almost everywhere and will be still present for millions of years, even all non-renewable energy sources might be depleted. It has no moving parts this is one of the major advantage of Photo Voltaic technology. Therefore, the Photo Voltaic system is very robust, it has a long lifetime and low maintenance requirements. And, most importantly, it is environmentally friendly power generation. The disadvantage of the PV system is that it can supply the load only in sunny days. Therefore, for improving the performance and supplying the power in all day, it is necessary to hybrid the Photo Voltaic system into another power generation systems or to integrate with the utility grid.

The integration of the Photo Voltaic system with the utility grid requires the PWM voltage source converter for interfacing the utility grid and results to some of the interface issues. A prototype current controlled power conditioning system has been developed and tested. This prototype sources 20 kW of power from a photovoltaic array with a maximum power point tracking control.

The disadvantage of this system is the need of high bandwidth current measurement transducers (dc to several times the switching frequency), and the need for relatively high precision in the reference signal generation. Hence, this increases the cost of the system. The inverters suitable for the PV system are central inverters, string inverters, module integrated or module oriented inverters, multi string PV inverter with new trends has been described below. If these solar inverters are connected with the grid, the control of these inverters can be provided using the phase locked loop. The need and benefits of the distribution technology has been presented in this paper. Single-phase Grid connected Photo Voltaic inverters with the control has been described with its advantages and disadvantages. The three-phase Photovoltaic power conditioning system with line connection has been proposed with the disturbance of the line voltage which is detected using a fast sensing technique.

The control of the system is provided through the microcontroller. Power electronic systems can also be used for controlling the solar inverter for interfacing the Solar Power Generation system with the grid the complete design and modeling of the grid connected Photo Voltaic system has been developed to supply the local loads.

This paper proposes the modeling of the grid connected Photo Voltaic system with the Constant Current Controller, which controls the solar inverter for interfacing the grid. The voltage level of DC voltage generated by the Photo Voltaic array is increased using the boost converter and then applied to the 3- ϕ , 2 level Solar inverter. The control of the solar inverter is provided through the Constant Current Controller. This controller uses the Phase Locked Loop and PI controllers. The Phase Locked Loop is used for tracking the phase angle of the grid voltage. The PI controller gains are chosen such that the Constant Current Controller generates the pulses for solar inverter according to the grid voltage. The proposed model is able to supply the 2 MW resistive loads and 30 MW, 2 MVA load the applicable criteria that follows.

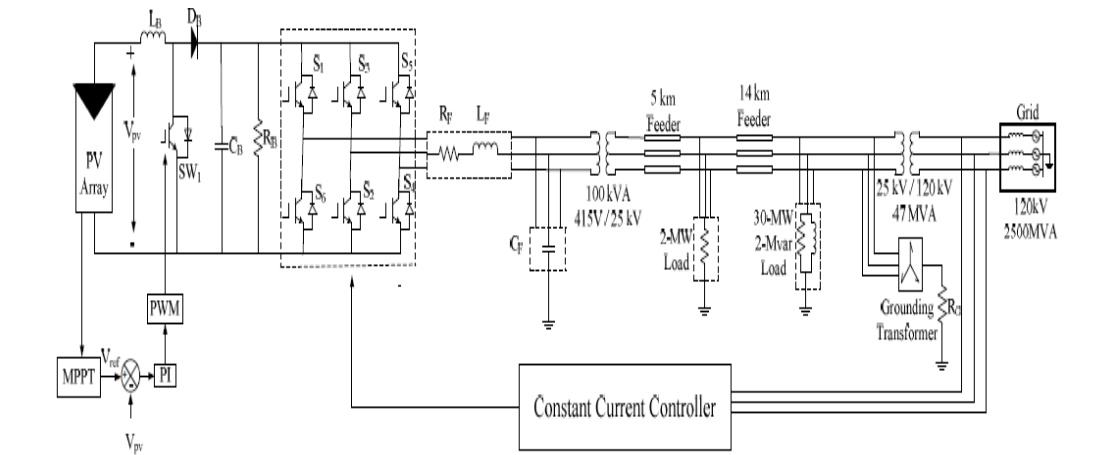

Fig 5 Circuit representation with constant current controller

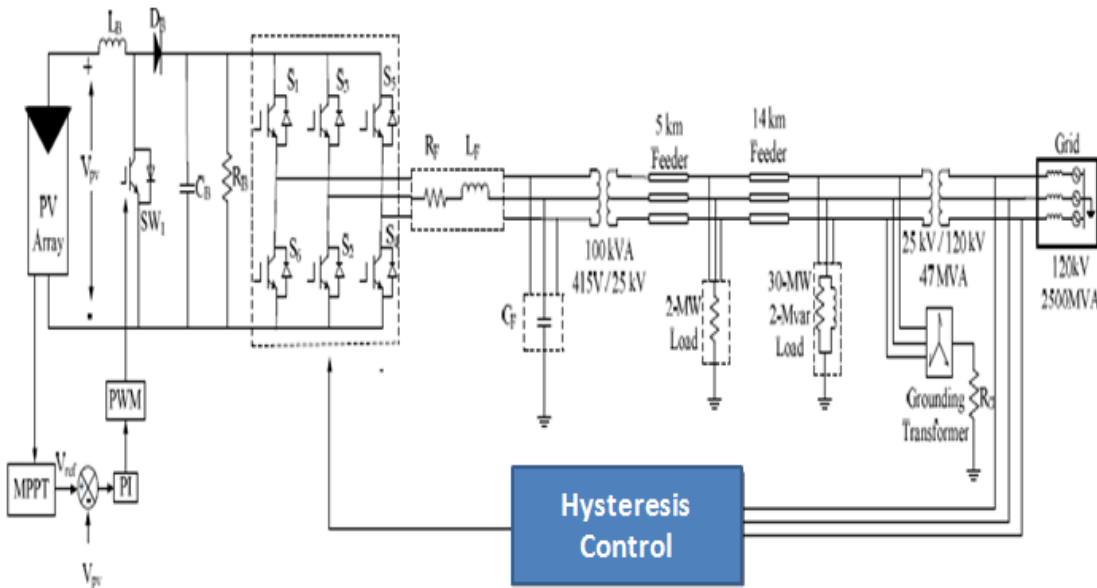

Fig 6 Circuit representation with hysteresis control.

This approach voltage is periodically given a perturbation & the corresponding output power is compared with that at previous perturbing cycle if the power increases due to that perturbation then the perturbation is continued in the same direction after peak power is reached at the next instant perturbation is reverses power will oscillates at peak power point in order to maintain power variation very small the perturbation size should be very small

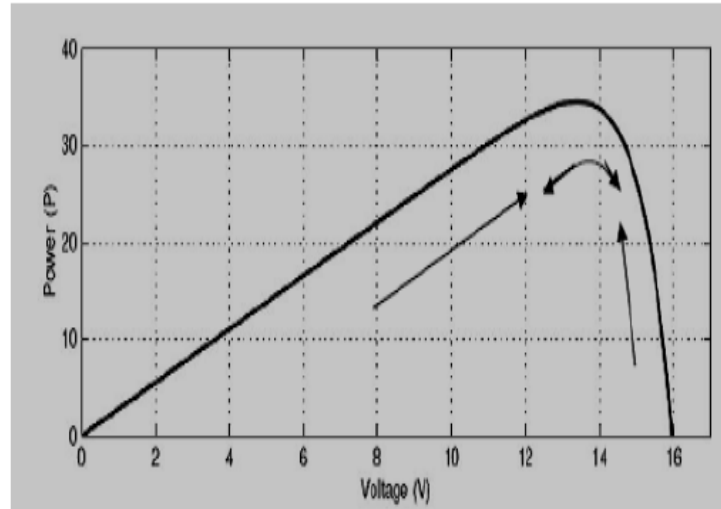

Fig 7 Power vs voltage representation

P&O method is the most frequently used algorithm to track the maximum power due to its simple structure and fewer required parameters. This method finds the maximum power point of PV modules by means of iteratively perturbing, observing and comparing the power generated by the PV modules. It is widely applied to the maximum power point tracker of the photovoltaic system for its features of simplicity and convenience. According to the structure of MPPT it is the relationship between the terminal voltage and output power generated by a PV module. It can be observed that regardless of the magnitude of sun irradiance and terminal voltage of PV modules, the maximum power point is obtained while the condition $dP/dV=0$ is accomplished. The slope(dP/dV) of the power can be calculated by the consecutive output voltages and output currents, and can be expressed as follows,

$$\frac{dP}{dV}(n) = \frac{P(n) - P(n-1)}{V(n) - V(n-1)} \quad (1)$$

$$\text{where } P(n) = V(n) I(n) \quad (2)$$

EQUATIONS:

V and I PV pannel voltage and currents

V_n and I_n are voltage and currents at nth intervals

V_b and I_b are voltage and currents at $(n-1)$ th intervals

$$P_n = V(n) * I(n)$$

$$P_b = V(n-1) * I(n-1)$$

$$\Delta p = P_n - P_b$$

$$\Delta v = V_n - V_b$$

$dP/dV = 0$ maximum power condition

if $dP/dV > 0$ then $D - \Delta D$

if $dP/dV < 0$ then $D + \Delta D$

$\Delta D =$ Perturbation $D =$ duty cycle from switch

MPPT SIMULINK MODEL

The below figure represents the maximum power point algorithm SIMULINK model using the MATLAB software

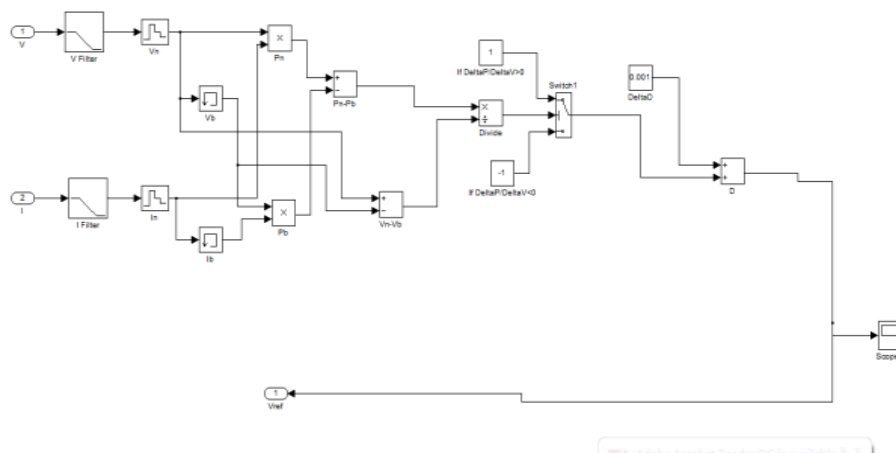

Fig 8 maximum power point algorithm SIMULINK model

BASIC DESIGN

There are commercially available MPPTs which are typically used for home solutions and buildings. These are not designed to withstand the harsh, fast-changing environmental conditions of solar car racing. Design of the customized MPPT will ensure that the system operates as closely to the Maximum Power Point (MPP) while being subjected to the varying lighting and temperature.

The inputs of the MPPT consisted of the photovoltaic voltage and current outputs. The adjusted voltage and current output of the MPPT charges the power supply. See Figure 2.

A microcontroller was utilized to regulate the integrated circuits (ICs) and calculate the maximum power point, given the output from the solar array. Hardware and software integration was necessary for the completion of this component.

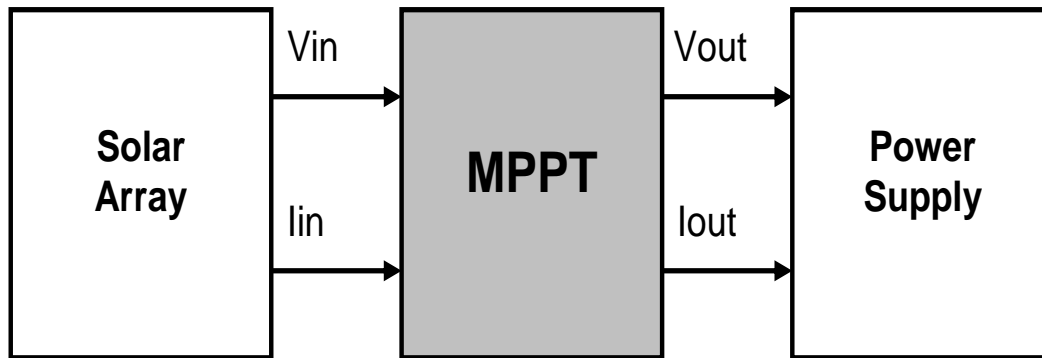

Figure 9: Basic Block Diagram

Overall Design Considerations

Many factors influenced the component selection and the design of the MPPT.

- In terms of optimal functionality, the theory of power conservation needed to be applied. The input and output voltage and current were calculated such that the power into and out of the MPPT was equal.
- To protect the photovoltaic array from damage, protection diodes were employed.
- Two 48V lead acid battery banks were utilized. Only one battery bank will be charged at a time. (The other will be employed to run other components of the car).
- In order to trickle charge the batteries, a voltage exceeding 48V must be fed to the bank. In this design, 50V was chosen to charge the power supply.
- To prevent damage and overcharging of the power supply, a FET was employed.

Solar Array Protection Block

The voltage divider took the voltage from the solar array and stepped it down to a maximum voltage of 4.08V. This prevented the ADC from “blowing out.” Without the voltage divider, the solar array would send too large of a voltage for the ADC to handle. Protection diodes were utilized to prevent the current from flowing back to the solar array and causing damage to it.

The PIC Microcontroller chosen had sufficient memory to meet the demands of the design. The ADCs were also included in the PIC, which reduced the amount of additional external parts.

The PIC contains a LCD screen, which enabled us to display the input and output voltages and currents. This enabled us to confirm the results of the calculations performed by the PIC. The structure of the LCD output was laid out as a menu. There were four main menu items, Voltage input from the solar array, current input from the solar array, voltage output from the MPPT and current output from the MPPT. See Figure 8.

NUMERICAL RESULTS

The simulation result are shows the concept of Comparison of Constant Current and Hysteresis Controlling techniques for PV system Integrated with Grid. The flowing figure represents simulink model for PV system integrated with grid using constant current controller. The following figure 5 represents simulink model for PV system integrated with grid using hysteresis controller. The following figure 6 represents simulink model of hysteresis controller to reduce the harmonics. The following figure 7 represents simulink design for hysteresis controller design. The following figure 8 represents simulation of proposed scheme at boost converter output. The following figure 9 represents simulation of proposed scheme at with filter. The following figure 10 represents simulation of proposed scheme at 2MW load. The following figure 11 represents simulation of proposed scheme at 30MW load. The following figure 12 represents simulation of proposed scheme at without filter. The following figure 13 represents simulation results using hysteresis controller.

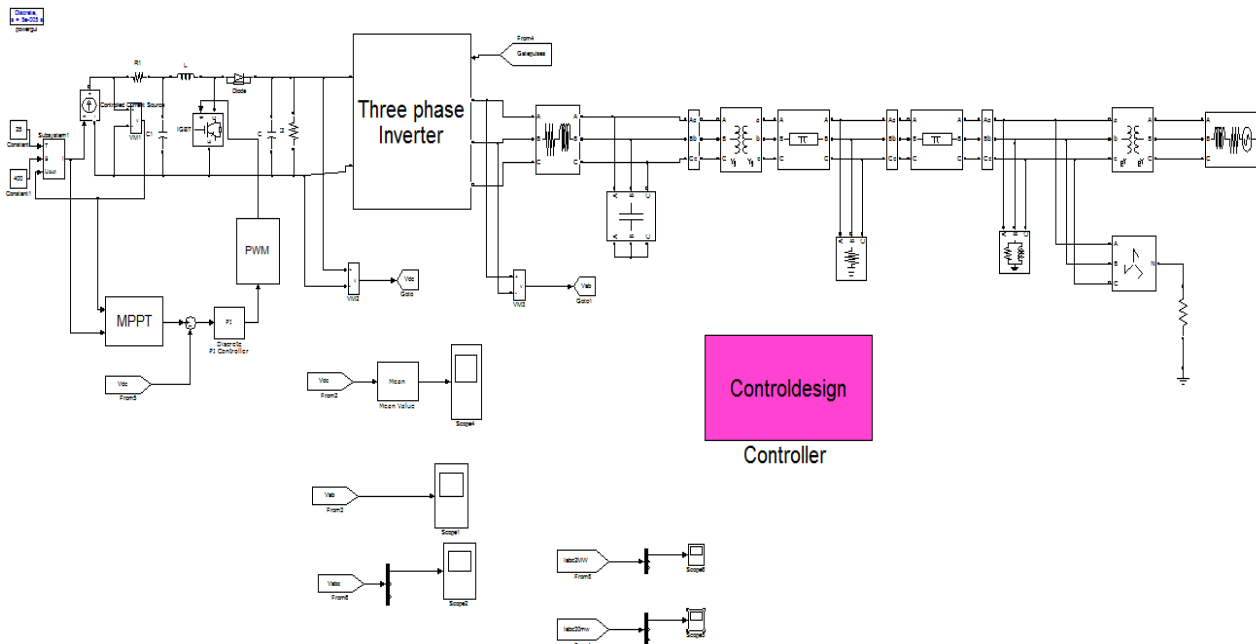

Fig 9 Simulink model for PV system integrated with grid using constant current controller

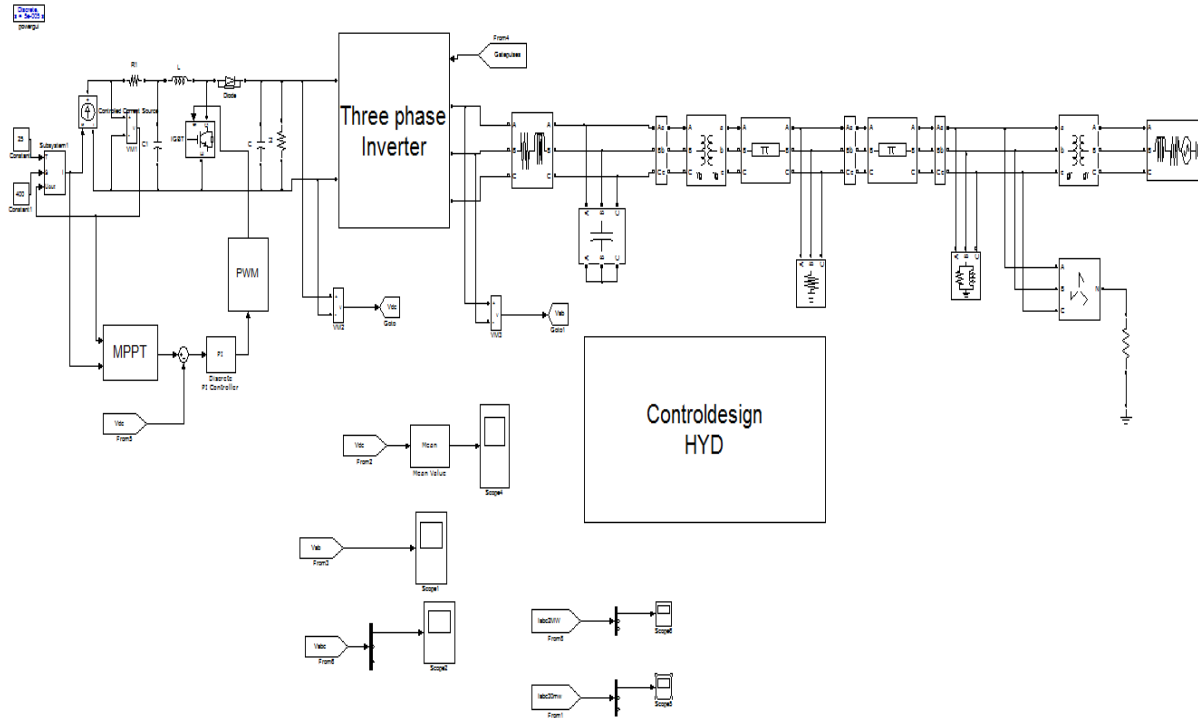

Fig 10 Simulink model for PV system integrated with grid using hysteresis controller

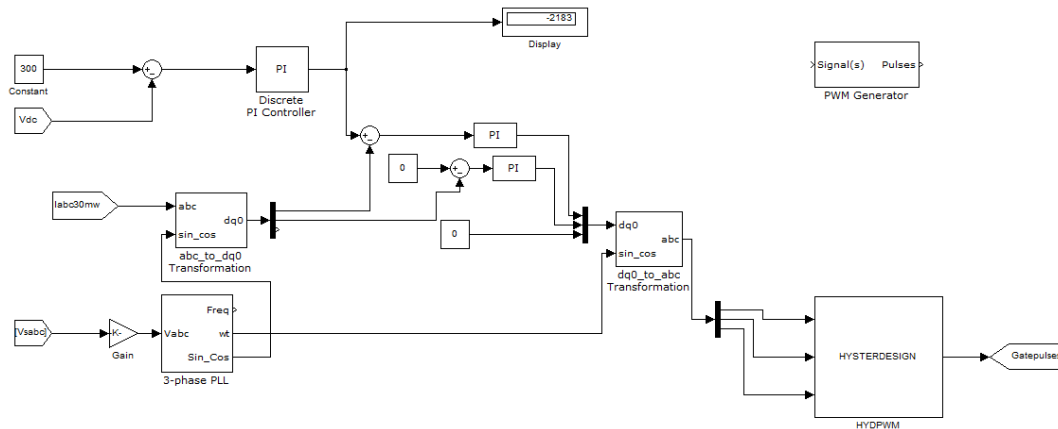

Fig 11 Simulink model of hysteresis controller to reduce the harmonics

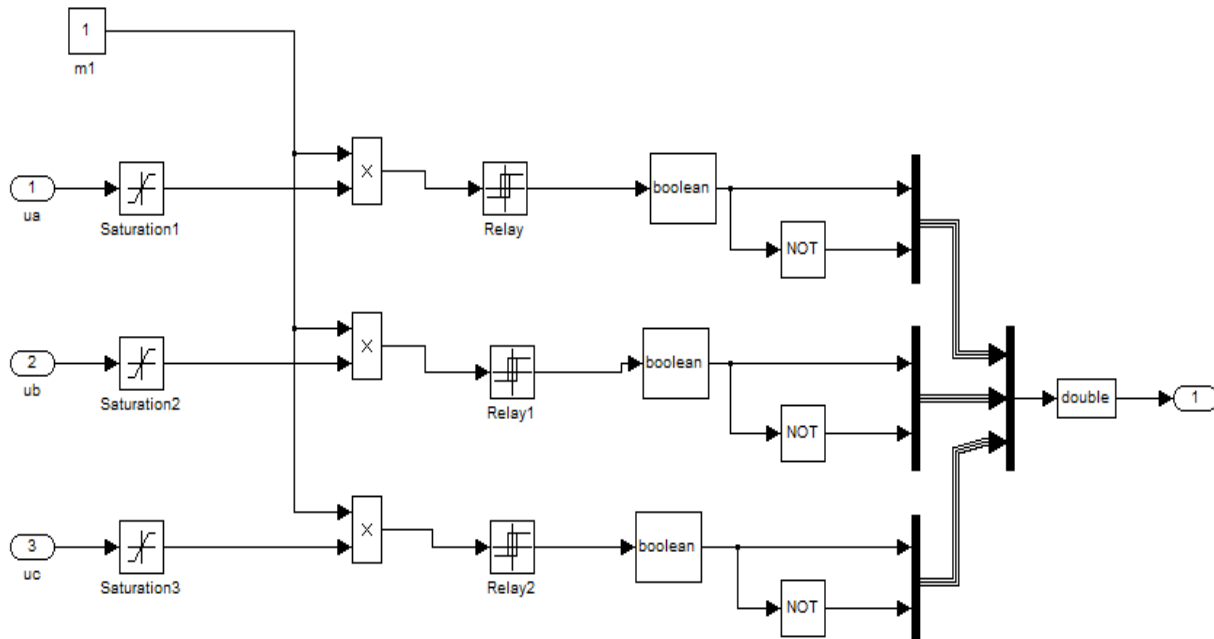

Fig 12 Simulink design for hysteresis controller design

Simulink is a software package for modeling, simulating, and analyzing dynamical systems. It supports linear and nonlinear systems, modeled in continuous time, sampled time, or a hybrid of the two. For modeling, Simulink provides a graphical user interface (GUI) for building models as block diagrams, using click-and-drag mouse operations. Models are hierarchical, so we can build models using both top-down and bottom-up approaches. We can view the system at a high level, then double-click on blocks to go down through the levels to see increasing levels of model detail. This approach provides insight into how a model is organized and how its parts interact. After we define a model, we can simulate it, using a choice of integration methods, either from the Simulink menus or by entering commands in MATLAB's command window. Using scopes and other display blocks, we can see the simulation results while the simulation is running. In addition, we can change parameters and immediately see what happens, for "what if" exploration.

The simulation results can be put in the MATLAB workspace for post processing and visualization. Simulink can be used to explore the behavior of a wide range of real-world dynamic systems, including electrical circuits, shock absorbers, braking systems, and many other electrical, mechanical, and thermodynamic systems.

Simulating a dynamic system is a two-step process with Simulink. First, we create a graphical model of the system to be simulated, using Simulink's model editor. The model depicts the time-dependent mathematical relationships among the system's inputs, states, and outputs. Then, we use Simulink to simulate the behavior of the system over a specified time span. Simulink uses information that you entered into the model to perform the simulation.

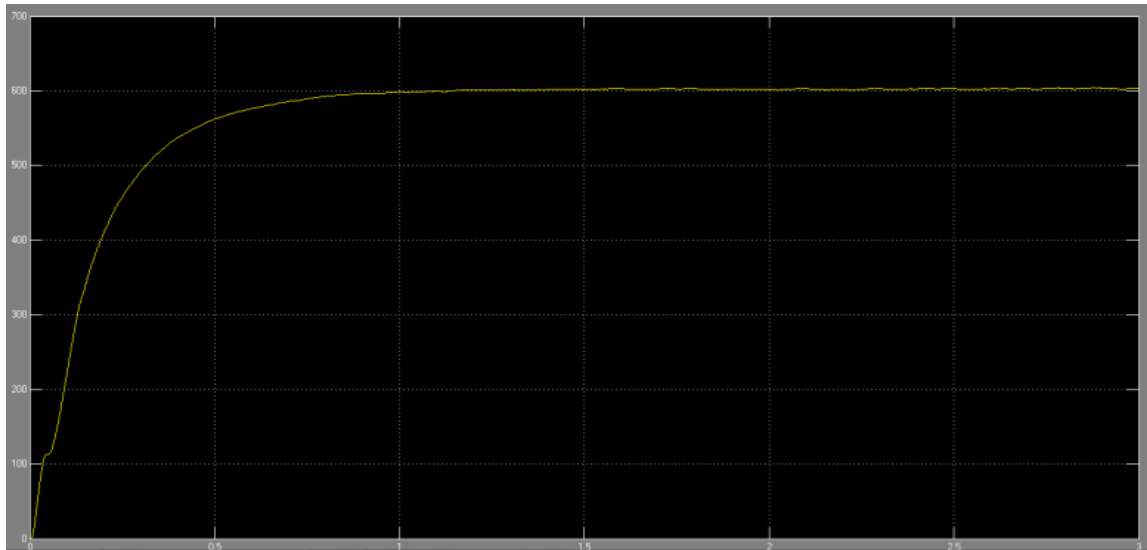

Fig 13 DC voltage delivered by the boost converter

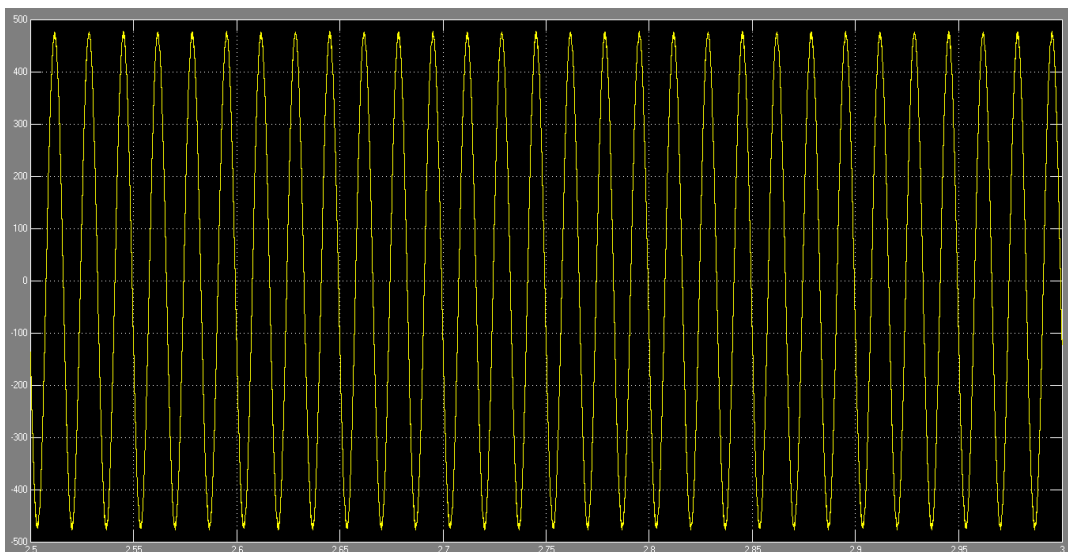

Fig 14 Inverter output voltage before filtering

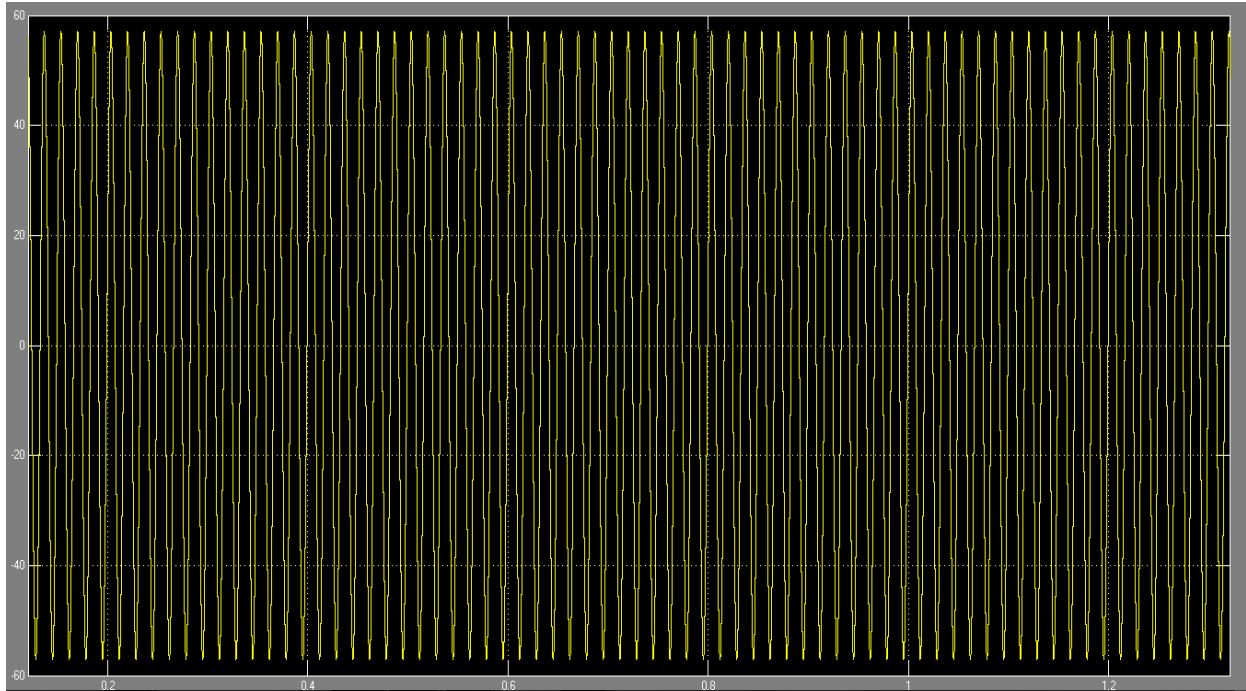

Fig 15 Load current for supplying 2MW load

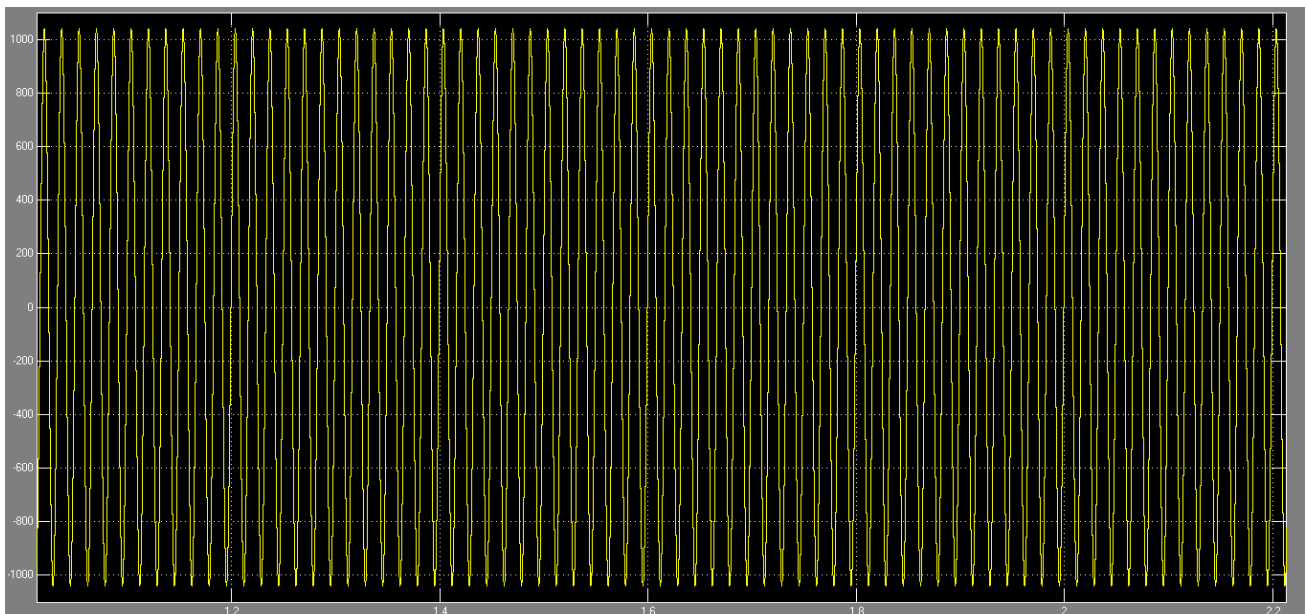

Fig 16 Load current for supplying 30MW load, 2 MVar

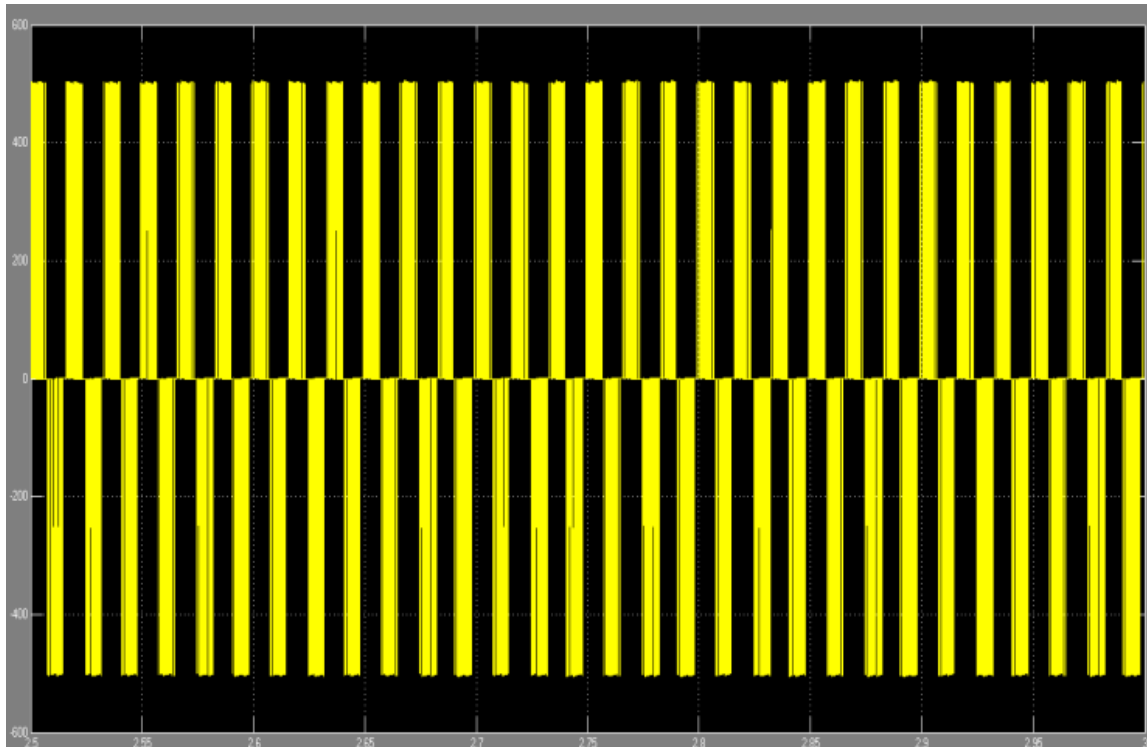

Fig 17 Inverter output voltage after filtering using constant current controller

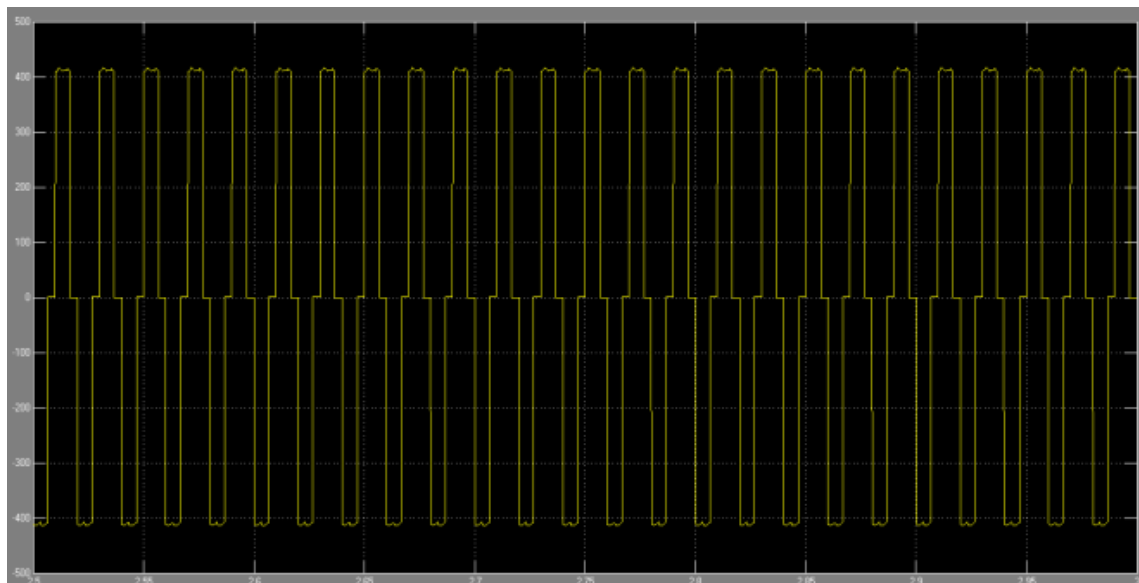

Fig 18 Inverter output voltage after filtering using hysteresis controller

CONCLUSION

The proposed adjusted dc-connect voltage controller with FBL method, utilizing INC MPPT, and real and receptive force controls with improved filter for pay for matrix voltage plunges has been tried at various insolation levels on a

real-time digital simulator (RTDS). Little sign examination of a PV system associated with an IEEE 33-bus distributed system is performed. The outcomes from reenactment and eigenvalue examination show the viability of the FBL controller contrasted and the controller without FBL. It is tracked down that the FBL controller beats the controller without FBL, as the FBL controller's performance is direct at various working conditions. With framework voltage plunge compensator filter, the dynamic performance is significantly better as far as less motions and bending in waveforms. Also, the eigenvalue examination shows that the impact of the unsettling influence in conveyance system is immaterial on PV system dependability as the eigenmodes of the PV system are practically autonomous of the dissemination system. This has been likewise affirmed by three-stage issue investigation of appropriation system in RTDS model. The controller performance is likewise approved on 4×375 kW PV units associated with the dissemination system.

REFERENCES

- [1] M. Oprisan and S. Pneumaticos, "Potential for electricity generation from emerging renewable sources in Canada," in *Proc. IEEE EIC Climate Change Technol. Conf.*, May 2006, pp. 1–10.
- [2] G. Petrone, G. Spagnuolo, R. Teodorescu, M. Veerachary, and M. Vitelli, "Reliability issues in photovoltaic power processing systems," *IEEE Trans. Ind. Electron.*, vol. 55, no. 7, pp. 2569–2580, Jul. 2008.
- [3] S. Jain and V. Agarwal, "A single-stage grid connected inverter topology for solar PV systems with maximum power point tracking," *IEEE Trans. Power Electron.*, vol. 22, no. 5, pp. 1928–1940, Jul. 2007.
- [4] F. Katiraei and J. Agüero, "Solar PV integration challenges," *IEEE Power Energy Mag.*, vol. 9, no. 3, pp. 62–71, May-Jun. 2011.
- [5] S. H. Ko, S. Lee, H. Dehbonei, and C. Nayar, "Application of voltage and current-controlled voltage source inverters for distributed generation systems," *IEEE Trans. Energy Convers.*, vol. 21, no. 3, pp. 782–792, Sep. 2006.
- [6] F. Blaabjerg, Z. Chen, and S. Kjaer, "Power electronics as efficient interface in dispersed power generation systems," *IEEE Trans. Power Electron.*, vol. 19, no. 5, pp. 1184–1194, Sep. 2004.
- [7] J. Carrasco *et al.*, "Power-electronic systems for the grid integration of renewable energy sources: A survey," *IEEE Trans. Ind. Electron.*, vol. 53, no. 4, pp. 1002–1016, Jun. 2006.
- [8] T. Esumi and P. Chapman, "Comparison of photovoltaic array maximum power point tracking techniques," *IEEE Trans. Energy Convers.*, vol. 22, no. 2, pp. 439–449, Jun. 2007.
- [9] S. Jain and V. Agarwal, "Comparison of the performance of maximum power point tracking schemes applied to single-stage grid-connected photovoltaic systems," *IET Electr. Power Appl.*, vol. 1, no. 5, pp. 753–762, Sep. 2007.
- [10] R. Mastromauro, M. Liserre, and A. Dell'Aquila, "Control issues in single-stage photovoltaic systems: MPPT, current and voltage control," *IEEE Trans. Ind. Informat.*, vol. 8, no. 2, pp. 241–254, May 2012.
- [11] R. Varma, B. Das, I. Axente, and T. Vanderheide, "Optimal 24-hr utilization of a PV solar system as STATCOM(PV-STATCOM) in a distribution network," in *Proc. IEEE Power Energy Soc. Gener. Meet.*, Jul. 2011, pp. 1–8.

- [12] A. Yazdani *et al.*, “Modeling guidelines and a benchmark for power system simulation studies of three-phase single-stage photovoltaic systems,” *IEEE Trans. Power Del.*, vol. 26, no. 2, pp. 1247–1264, Apr. 2011.
- [13] F. Delfino, G. Denegri, M. Invernizzi, and R. Procopio, “A control algorithm for the maximum power point tracking and the reactive power injection from grid-connected PV systems,” in *Proc. IEEE Power Energy Soc. Gener. Meet.*, Jul. 2010, pp. 1–7.
- [14] L. Wang and Y.-H. Lin, “Dynamic stability analyses of a photovoltaic array connected to a large utility grid,” in *Proc. IEEE Power Eng. Soc. Winter Meet.*, Jan. 2000, vol. 1, pp. 476–480.
- [15] B. Tamimi, C. Canizares, and K. Bhattacharya, “Modeling and performance analysis of large solar photovoltaic generation on voltage stability and inter-area oscillations,” in *Proc. IEEE Power Energy Soc. Gener. Meet.*, Jul. 2011, pp. 1–6.
- [16] W. Du, H. Wang, and R. Dunn, “Power system small-signal oscillation stability as affected by large-scale PV penetration,” in *Proc. IEEE Int. Conf. SUPERGEN*, Apr. 2009, pp. 1–6.
- [17] S. Balathandayuthapani, C. Edrington, S. Henry, and J. Cao, “Analysis and control of a photovoltaic system: Application to a highpenetration case study,” *IEEE Syst. J.*, vol. 6, no. 2, pp. 213–219, Jun. 2012.
- [18] A. Yazdani and P. Dash, “A control methodology and characterization of dynamics for a photovoltaic (PV) system interfaced with a distribution network,” *IEEE Trans. Power Del.*, vol. 24, no. 3, pp. 1538–1551, Jul. 2009.
- [19] G.-C. Hsieh and J. Hung, “Phase-locked loop techniques—A survey,” *IEEE Trans. Ind. Electron.*, vol. 43, no. 6, pp. 609–615, Dec. 1996.
- [20] “Voltage Characteristics of Electricity Supplied by Public Distribution Systems,” CENELEC, Brussels, Belgium, EN-50160, 1994.
- [21] V. N. Lal, M. Siddhardha, and S. N. Singh, “Control of a large scale single-stage grid-connected PV system utilizing MPPT and reactive power capability,” in *Proc. IEEE Power Energy Soc. Gener. Meet.*, Jul. 2013, pp. 1–5.
- [22] R. Teodorescu, M. Liserre, and P. Rodriguez, *Voltage-Sourced Converters: Modeling, Control, and Applications*. West Sussex, U.K.: Willy, 2010.
- [23] E. S. Jean-Jacques and L. Weiping, *Applied Nonlinear Control*. Englewood Cliff, NJ, USA: Prentice-Hall, 1991.
- [24] J. J. Grainger and W. D. Stevenson, *Power System Analysis*. Hightstown, NJ, USA: McGraw-Hill, 1994.
- [25] P. Kundur, *Power system Stability and Operation*. New York, NY, USA: McGraw-Hill, 1994.
- [26] *IEEE Standard for Interconnecting Distributed Resources with Electric Power Systems*, IEEE Std. 1547.2-2008, Apr. 2009.