

A Hybrid Cascaded Multilevel Converter for Battery Vitality Administration Connected In Electric Transport for Battery Energy Management

Srinivas Gadde¹, Bhanu Ganesh Lukka² and Shankar Mahesh Kumar Gali³

^{1,2,3}Department of Electrical Engineering, Vignan Institute Of Technology and Science (VITS) Deshmukhi, Yadadri,

Abstract. In the (EV) electrical vehicles energy storage system plays a crucial role. Normally, in electrical vehicles large number of cells connected in series to increase the output voltage for driving motor. Battery cells will have different electrochemical characteristics which cause the difference in terminal voltage (or) (SOC) state of charge imbalances between the each cell. In this paper cascaded multilevel converter which involves in both management of energy and motor drives proposed for electric vehicles and each battery cell can be controlled to the circuit or bypassed by a half-bridge converter. All these half-bridges are cascaded to the output staircase shape dc voltage. And H-bridge converter will be used to change the direction of dc bus voltage to convert it ac voltage. The advantage of the converter will have multilevel voltages with small dv/dt and lesser harmonics. So, it is helpful to make better performance of motor drives. Through separate control according to state of charge of each cell the energy utilization of batteries can be improved drastically. By using the fuzzy logic controller for current measurement the THD can be reduced drastically. In order to verify the performance of proposed converter simulation done in matlab.

1 Introduction

In electrical vehicles, energy storage system plays a crucial role. Lead-acid batteries or lithium batteries are most popular one because of their suitable energy density and cost. Due to low voltage of these kind of batteries need to be connected in series to get appropriate voltage requirement for driving motor [1-2]. Normally, there are two kinds of equalization circuits are used. First one which consumes the unused energy on parallel resistance, to keep the voltage of all cells equal. Second kind of equalization circuit, it composed of a group of transformers or inductances and converters, which can realize transfer of energy between cells. The energy in cells with more terminal voltage or state of charge can transferred to other cells to realize state of charge and voltage equalization [1]. The demerit is that it require lot of inductances and isolated multiple winding transformers in this topology and it leads to complexity in operation of converter [5]-[12]. So, some studies have been performed to simplify the circuit and also to improve balance speed by multiphase equalization [9]-[13]. Such as zero current and zero voltage switching also performed to reduce the loss of equalization circuit [13].

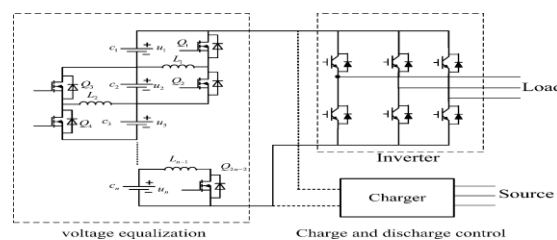

Fig.1. Obsolete power storage system with inverter and voltage equalization circuit.

Now-a-days multi converters are mostly used in the medium voltage and high voltage motor drives [5]-[9]. If their isolated direct current sources or flying capacitors are replaced by battery cells and these battery cells are cascaded in series combining with converters instead of connecting directly in series. [13]-[14].

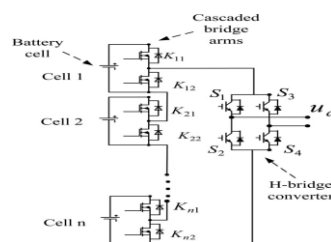

Fig.2. Hybrid cascaded multilevel converter.

* Corresponding author: gadde.cnu@gmail.com

The proposed Hybrid cascaded multilevel converter in this paper, it can realize the SOC or terminal voltage between the cells. The proposed converter can realize the discharging and charging control of the battery cells. And we get the desired AC voltage at the output of H-bridge converter So, it does not require additional battery chargers or inverters in any circumstances. The obtained ac output voltage of the converter is multilevel voltage and the number of voltage levels is directly proportional to number of battery cells connected in cascaded.[1]

2 Hybrid Cascaded Multilevel Converter Topology

It is one of the most popular methods for voltage balancing circuit through energy transfer as shown in the figure.1 [5], [19] it consist of an Half bridge arm and inductance between the two cells. So, number of inductance is $n-1$ and number of switching devices are $2*n-1$.where n stands for number of battery cells. And moreover, this circuit requires an additional inverter for the motor drive and a charger is required for recharging the battery. [1]

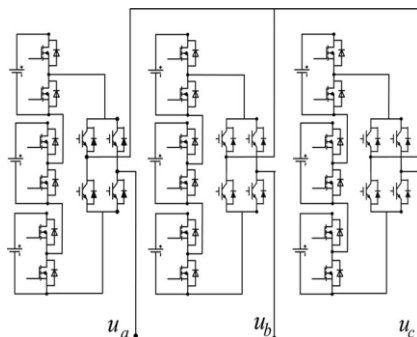

Fig.3. Three phase hybrid cascaded multilevel converter.

From the figure it is clear that output of the cascaded Half bridges is the dc bus is connected to the dc input of H-bridge. In the above circuit, each half bridge makes the battery cell involvement in voltage produced or bypassed to the circuit. H-bridge converter is equals to base frequency of desired alternating current voltage.[1]

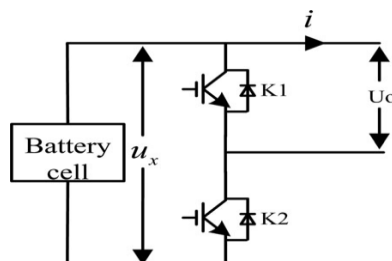

Fig.4. Output current and voltage of the battery.

There are two kinds of power electronics devices are proposed in this circuit. MOSFETs and IGBTs [1].The proposed topology of three phase converter is shown in the figure.3. if 'n' number of battery cells used in each phase, then the number of devices used in H-bridge each phase is $2*n$. when compared to explained in [1].

3 Control Method of the Converter

In the cascaded half bridges are defined by $S_x=1$ upper switch is conducted and lower switch will be in off state. $S_x=0$ lower switch is conducted and upper switch will e in off state. The m_x is the modulation ratio of each half bridge defined as average value of the switching state in a pulse width modulation. The half bridge is shown in figure4. When $S_x=1$, battery is connected to the circuit and is charged or discharged it is determined by direction of external current. When $S_x=0$, battery is bypassed from the circuit, it is neither charged nor discharged. Half bridge switching state working principle is between $0 < m_x < 1$. Instantaneous power discharge is

$$p = S_x \cdot u_x \cdot i \quad (1)$$

Here I is the charging current of the bus and u_x is voltage of the battery cell.H-bridge is simply used to change the direction of dc bus voltage, so the reference voltage obtained at the dc bus is absolute value of alternating current reference voltage , it s similar to half sinusoidal wave at the steady state. From this we can say that not all the battery cells are needed to supply to the load at sometime

In the cascaded multilevel converter there are two modulation methods are used: they are carrier-cascaded PWM and phase shift PWM. Since, the SOC or terminal voltage balance control is realized by PWM. Hence, carrier-cascaded PWM is best suitable since modulation ratio of difference between different battery cells is used for balance control [16-17].

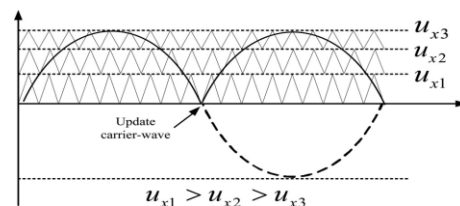

Fig 5. Carrier wave while discharging

In order to reduce EMI and dv/dt here only one half bridge allowed to change the switching state at a same time continuous reference voltage. Hence, carrier wave is rearranged when the modulation carrier wave is zero and rearranged carrier wave is zero. Here carrier wave is rearranged only two times during one reference voltage cycle as shown in the figure5. The cells SOC and voltage vary slowly during normal usage soothe carrier wave updated by the base frequency is enough for SOC and voltage balance.

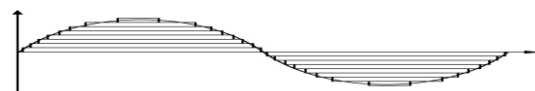

Fig. 6. Base frequency

Here all the half bridges are worked at the base frequency as shown in the figure 6, where the alternating current output voltage is approaches to sinusoidal wave it is similar to the multilevel converter [15].

If one of the battery cell got damaged, the half bridge is bypassed, and it will be no influence on the other battery cells. The output voltage of the bypassed battery cell is reduced. And we need to reduce the three phase reference voltage to fit to the output voltage ability. In order to improve the output voltage, the neutral shift three phase is adopted. Which is explained in [17-18].

4 Losses Analysis and Comparison

The circuit topology and voltage balance of the proposed circuit is quite different from the traditional circuit shown in the figure.4. in the traditional circuit method the energy transfer circuit used for the voltage balance and three phase two level DC-AC converter used for discharging control. In this proposed Hybrid cascaded circuit, discharging control is associated with the H-bridge converter and cascaded Half-bridges are used for voltage control. For this two circuits, the conduction losses and switching losses are quite different. In order to get clear thought, the conduction and switching losses are analyzed as follows:

$$J_{Loss} = J_{C_B} + J_{C_H} + J_{S_H} + J_{S_B} \quad (2)$$

Where J_{C_B} and J_{C_H} are conduction losses of cascaded half bridges and H-bridge converters and J_{S_B} and J_{S_H} are switching losses of Half bridge and H-bridge converter .

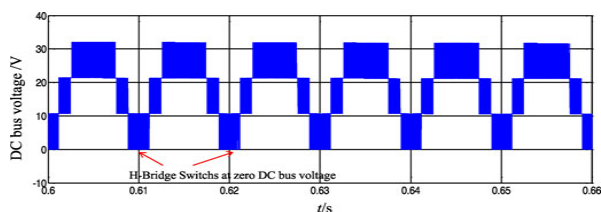

Fig 7. Dc output voltage of the cascaded half bridges

Table 1. Switching and conduction losses comparison of traditional and proposed circuit

		loss in a single switching course	Conduction loss power
Traditional circuit	Energy transfer circuit	determined by imbalance	determined by imbalance
	3-phase inverter legs	$J_{s,t}$	$P_{c,t} = I^2 R_{c,t}$
Proposed novel circuit	Cascaded half-bridges	Much less than $J_{s,t}/n$	$P_{c,b} = I^2 R_{c,b} \cdot n$
	H-bridges	Near zero	$P_{c,h} = I^2 R_{c,h} \cdot 2$

5 Charging Method

In the proposed converter circuit, a dc voltage source is needed for charging the battery. The charging voltage and current can be controlled by the proposed circuit itself according to necessity of the battery cells. Circuit diagram of charging circuit is shown in the figure.8. in order to switch the dc bus from H-bridge the dc voltage source, a circuit breaker is used. Further, a filter inductor is also used in order to realize the current

control, which is connected in the series. The dc voltage source can also be realized by using capacitor and H-bridge as shown in figure.9. Here H-bridge which is worked as a AC-DC converter i.e., rectifier by using diodes and a steady state dc voltage is produced by using capacitors. While charging the battery, the charging current needs to be controlled. The current state equation is

$$R_f + L_f \frac{dx}{dt} = u_{dc} - u_{char} \quad (3)$$

Where u_{charge} the voltage of dc source, u_{dc} is the dc bus output voltage of cascaded Half bridge converter and L_f , R_f are the inductance and resistance of the inductive filter between the dc source and cascaded Half bridges. In this charging method, the bus voltage must be smaller than that of the possible maximum value of the dc bus voltage.

$$u_{charge} \leq u_{dc} \leq n \cdot u_0 \quad (4)$$

Where u_0 is the discharging cut-off voltage of the battery cell and n is the number of cascaded half bridges in each phase.

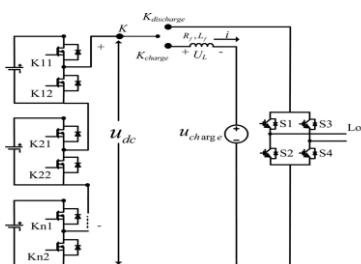

Fig 8. Charging circuit of cell with dc source

While charging cycle their might be variation in the voltage of battery cells and the dc source voltage, to make the charging current constant and the switching states of cascaded half bridges are switched. Circuit of current control scheme is shown in the above figure.10

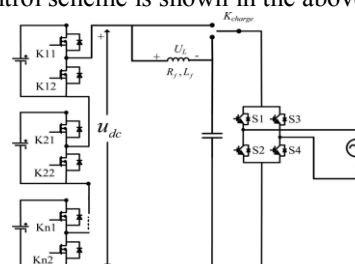

Fig 9. Charging circuit of cell with ac source

A proportional integral (PI) controller is used to make the constant current by charging the dc output voltage of the cascaded cells. [1]

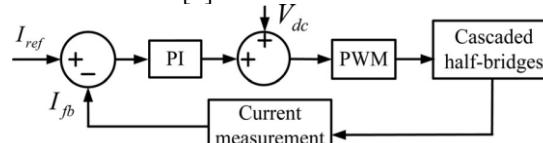

Fig 10. Current control scheme for battery charging

The arrangement of carrier wave in charging state is opposite to that of discharging state. The battery cells with higher voltages will be arranged in top levels in order to make them absorb less energy. Similarly, the battery cells with lower voltage are placed at the bottom to make them absorb more energy from the dc source.

During the discharging state similar analysis is performed and the positions of the carrier waves is shown in the figure.9. During the regenerative braking mode of the motor drives i.e., when electric vehicles EV is breaking, the battery cells are charged, hence the modulation will be changed to charging state/mode as shown in the figure.11

Energy charged in the cell battery is same as the traditional one i.e.,

$$P_{\text{Charge}} = U_x \cdot i \cdot S_x \quad (5)$$

Here i is the charging current controlled by the scheme and S_x is the switching state of the bridge arms.

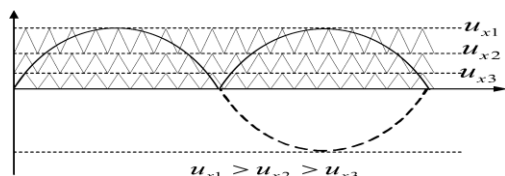

Fig. 11. Carrier wave during charging

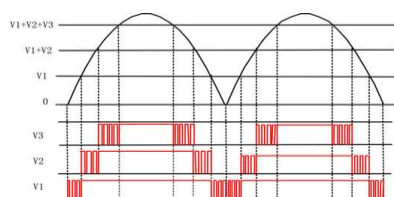

Fig. 12. Intermediate charging current of cells

Whenever, there is variation in the reference dc bus voltage, like half wave sinusoidal waveform, because of the pulse width modulation all the battery cells are intermittently charged. This method is similar to the fast charging method of the battery cells and to improve the charging speed. Charging current proposed in this converter will be more than the ordinary charging principle. Whenever steady state dc source is used to change the battery stack, we get referenced bus voltage nearly constant. In order to realize this kind of fast charging method of battery cell, the carrier wave should be forced to exchange its position from time to time which is not arranged by terminal voltages of state of charge any more. In order to get the intermittently charging current the switching state of half bridges will be charged.

6 Results of Experiment

In order to verify the performance of proposed converter and its control method, an three phase 3-cells cascaded circuit simulation done in matlab. It is shown in the figure 2. In this we used lead-acid battery module with 16.67v. Since, it is difficult to estimate the SOC of battery cells, the terminal voltages are used for the PWM carrier wave arrangement. Cascaded half bridges are designed with MOSFETs and H-Bridge designed with IGBTs.

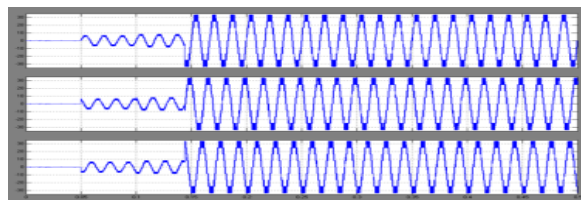

Fig 14. Three phase output multilevel voltage

Table. 2. Induction motor parameters

Paramter	Value
Rated power	0.55kW
Rated line voltage	380V
Rated line current	1.5A
Rated frequency	50Hz
Number of pole paires	2
Rated speed	1390rpm

Three phase output voltage is shown in the figure 14. In each phase there are nine levels and the waveform is more similar to ideal sinusoidal waveform than the traditional two-level inverter.

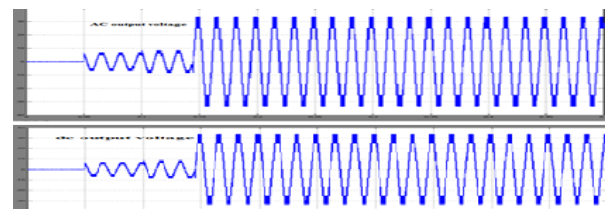

Fig 15. ac and dc output voltage while motor acceleration

An induction motor driven with (VVVF) variable-voltage-variable-frequency control method is applied. The parameters of above induction motor is shown in given table.2

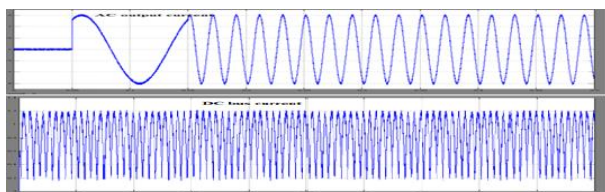

Fig 16. Output dc and ac current while motor acceleration.

The ac voltage, dc bus voltage, dc bus current, output are shown in figure15 and 16, it indicate that whole process from starting to stable state of induction motor. From the figure.15, it is clear that motor speed, its voltage levels are increasing. The stator current in the motor is shown in the figure.16 is a improved sinusoidal waveform, it will reflects the control performance of the motor.[1]. But, here the phase ac current will change its direction after certain period of time, hence the direction of dc bus is reversed when the current and phase voltage direction are different. [1]

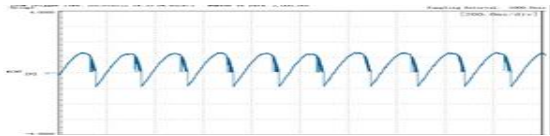

Fig 17. Dc bus current with load

The dc bus current is shown in figure.17 if there is some loads and it has some reverse current. This reverse current is greatly reduced by means of average power flowed from converter to the motor.

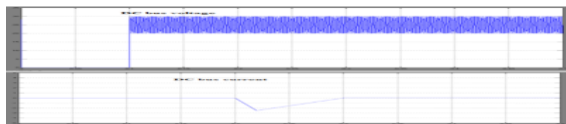

Fig 18. Dc bus current and dc bus voltage when connected with dc source

Figure 18 shows the dc bus current and dc bus voltage when the dc source was connected. It shows when dc source was connected. In the figure 17, there are two half bridges working at $S_x=1$ and third one working in switching state.

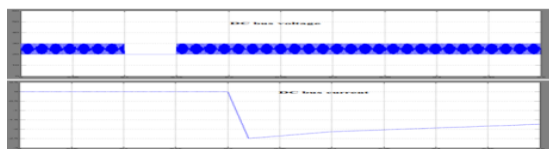

Fig. 19. DC charging current and bus voltage while charging current being give PI controller

When the charging current reference given, the dc voltage reduce first to establish with dc current is shown in the figure 19. The resistance of the filter inductance is very small, the voltage drop on the filtered inductance through dc current is almost near to zero, and the dc bus voltage becomes same as non-charging state.

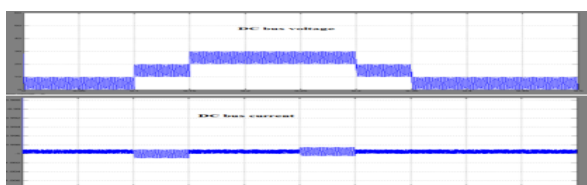

Fig. 20. DC bus current and bus voltage while dc source voltage change

At the time of battery charging, if dc source voltage is charged, the charging current control results is shown in figure 20. As we did not use feed forward compensation in our system the output has some ripples during the course of time.

7 Proposed Work

7.1 FUZZY LOGIC CONTROLLER

A fuzzy control system is based on fuzzy logic i.e., a mathematical system which takes input analog values in the form of logical variations, that takes continuous

values between 0 and 1 compared to digital logic which can operate on discrete value either 0 or 1 i.e., false or true respectively.

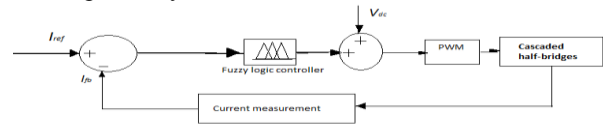

Fig 22. Current controlling scheme for battery charging using fuzzy logic controller

Total Harmonic Distortion (THD) in the current measurement scheme is reduced to 1.39% by using a fuzzy logic controller and THD present in a PI controller is 6.27%.

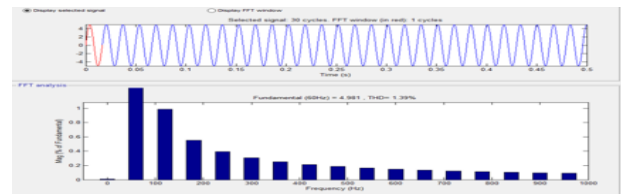

Fig. 21. THD of ac output current by FFT analysis for fuzzy logic controller

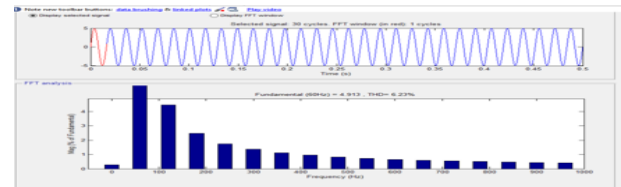

Fig. 22. THD of ac output current by FFT analysis for PI controller

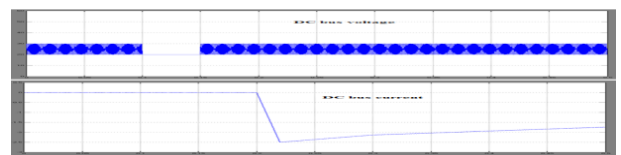

Fig. 23. DC charging current and bus voltage while charging current being given –fuzzy controller

8 Conclusion

In the proposed paper, hybrid cascaded multilevel converters can realize the discharging and charging by battery cells, while SOC or terminal voltage balance can be realized at the same time. By its modular structure, it is suitable for n number of cascaded levels and it is also suitable for energy storage systems with lower voltage battery modules or cells. If there is any fault in a battery module, it can be bypassed without affecting the others which are running, hence this converter has good fault controlling capability, so it can improve the reliability of the system. Here, we used a dc current control method using a fuzzy logic controller for battery cells charging and discharging with external ac or dc, which is studied.

where additional charger is not required for constant current control. Simulation results are verified.

References

1. Zedong zheng, member, IEEE, kui wag, member, IEEE, lie xu, member IEEE and yongdong li, member "A hybrid cascaded multilevel converter for battery energy management applied in electric vehicle" IEEE 2014.
2. S.M.Luick, J.Cao, R.C.Bnasal, F.Rodriguez and A.Emadi, "energy storage systems for automotive applications" *IEEE Trans.Ind.Electron. vol.55 no.6 pp, Jul 2008*.
3. H.M.Zhang and S.P.Ding "Application of synergic electric power supply in HEV" in *8th world Congr. Intelligent control action, 2010*.
4. A.Emadi, Y.J.Lee and K.R.Rajashekara, "power electronics and motor drives in electric, hybrid electric and plug-in hybrid electric vehicles" *IEEE Trans. Ind. Electron., vol.55, no.6- June 2008*
5. K.Joghoon, S.Jhongwon, C.Changyoon, and B.H. Cho, "Stable configuration of a Li-ion series battery pack based on a screening process for improved voltage/SOC balancing," *IEEE Trans. Power Electron., vol.27, no.1, pp.411-424, Jan 2012*
6. L.Yuang-Shung, T.Cheng-En, k.Yi-Pin, and C.Ming-Wing, " Charge equalistion using quasi-resonant converters in battery string for medical power operated vehicle application," in *Proc. Int.Power Eletron. Conf., 2010 pp. 2722-2728*.
7. Y.C. Hsieh, C.S.Moo and W.Y.Ou-Yang, "A bi-directional charge equalization circuit for series-connected batteries ." in *Proc. IEEE Power Electron. Drives Syst.,2005,pp.1578-1583*.
8. S.Yarlagadda, T.T.Hartley, and T.Hussain, "A battery management system using an active charge equalization technique based on DC/DC converter topology," in *Proc. Energy Convers.Congr.Expo.,2011,pp.1188-1195*
9. K.Chol-Ho, k.Young-Do, and M. Gun-Woo, "Individual cell voltage equalizer using selective two current paths for series connected Li-ion battery strings." In *Proc. Energy Convers. Congr.Expo.2009,pp.1812-1817*.
10. H.Shen, W.Zhu, and W.Chen, "Charge equalization using magnetic winding model for lithium ion battery string." In *Proc. Asia-pacific power Energy Eng.Conf.2010,pp.1-4*.
11. P.Sang-Hyun, P.Ki-BUM, K.Hyoung-suk, M.Gun-woo, and Y. Myung-Joong, "Single-magnetic cell-to-cell charge equalization coverter with reduced number of transformer windings." *IEEE Trans. Power Electron., vol.27 no.6,pp, 2900-2911, Jun 2012*.
12. K.Chol-Ho, K.Moon-Ypumg and M.Gun-woo,"A modularized charge equalizer using a battery monitoring IC for series-connected Li-Ion battery strings in electric vehicles" *IEEE Trans. Power Electron., vol.28.no.8, pp.3779-3789, Aug.2013*.
13. L.Maharjan, S. Inoue, H. Akagi, and J.Asakura, "state-of-charge(soc)- balancing control of a battery energy storage based on a cascaded PWM converter" *IEEE Trans. Power Electron., vol.24,no.6,pp.1628-1636, Jun.2009*.
14. L.Maharjan, T.Yamagishi, and H.Akagi. "Active-power control of individual converter cells for a battery energy storage system based on a multilevel cascade PWM controller," *IEEE Trans. Power Electron., vol.27,no.3, pp. 1099-1107, Mar.2012*.
15. K. Ilves, A.Antonopoulos, S.Norrnga, and H.Nee, "A new modulation method for the modular multilevel converter allowing fundamental switching frequency," *IEEE Trans. Power Electron., vol. 27, no.8, pp.3482-3494, Aug.2012*.
16. B.P.McGrath and D.G.Holmes, "enhanced voltage balancing of a flying capacitor multilevel converter using phase disposition (PD) modulation," *IEEE Trans. Power Electron., vol.26, no.7, pp.1933-1942, Jun.2011*.
17. L.Maharjan, T. Yamagishi, H.Akagi, and J.Asakura, "fault tolerant operation of a battery –energy-storage system based on a multilevel cascaded PWM converter with star configuration," *IEEE Trans. Power Electron. vol.25, no.9, pp.2386-2386, Sep.2010*.
18. M.Ma, L.Hu, A.Chen, and X.He, "Reconfiguration of carrier-based modulation strategy for fault tolerant multilevel inverters," *IEEE Trans. Electron., vol.22.no.5,pp.2050-2060,Sep.2007*.
19. S.Gui-Jia, "Multilevel DC-link inverter," *IEEE Trans. Ind. Appl., vol.41,no.1,pp.848-854, jan-2005*.