

Fuzzy-Based Voltage Sag Enhancement of Grid Connected HybridPv-Wind Power System Using Battery and SMEs Based Dynamic Voltage Restorer

Bhanu Ganesh Lukka ¹, V. Mythri ², M. Naveen Kumar ³, G. Ranjith ⁴, CH. Krishna Sai ⁵

Assistant Professor, Department of Electrical and Electronics Engineering

Vignan Institute of Technology and Science, Hyderabad, Telangana

Department of Electrical and Electronics Engineering, VGNT, Hyderabad, Telangana

Abstract

The micro grid (MG), if properly designed and with an efficient control system, is a platform for the development of distributed and renewable energy-based products. Because MG inertia is low due to its small structure and low resistance to change, it is very difficult to maintain frequency and voltage stability, especially in the island state. Unlike the power grid, inverter-based distributed generation is the main source of MGs. Due to the low response rate of primary energy sources in distributed generation, these productions, even if they have an efficient control system, alone cannot maintain MG stability, so by using electrical energy storage sources and D-STATCOM along with distributed generation, in This research proposes an interactive and multilevel structure for voltage and MG frequency stability. This structure greatly speeds up the MG response to perturbations through an interactive control system. The proposed structure has been implemented and evaluated by MATLAB software onMGs that can be used in both connection and island modes in the presence of a renewable wind source.

Keywords

Micro, Generation, MGs. Perturbations, MATLAB, tools

1.INTRODUCTION

1.1 General

While the global demand of energy is increasing constantly, the use of classic source of

energy like oil and coal becomes problematic contributing among other things to

climate change. One solution to address climate change is the use of clean renewable energy sources among other solar and wind. Most areas in South Africa average more than 2500 hours of sunshine per year with an annual 24 hour solar radiation of approximately 220 W/m², compared with 150 W/m² in the USA and averaging 100 W/m² for Europe. This makes South Africa's solar radiation resource one of the highest in the world. The progress in power electronics facilitated integration of these renewable energy sources either grid or as stand-alone for small scale use. Historically, the integration was started with wind farms. When the price for photovoltaic panels became affordable, the penetration of PV became to be used more often but not necessarily at the same level of power as wind. For medium to high power the PV's are modularly used. Many studies propose small power integration (few kW) for both wind and solar PV as hybrid stand-alone systems. Other studies added fuel cells and batteries creating the concept of multi-port system.

Apart from methods of integration a continuous attention was towards controlling the systems in order to maximise solar PV efficiency, or wind. Stability of renewable system was also under scrutiny. Double or multi-port integration systems for renewable have been previously proposed. The communality of all these studies proposed parallel connection of various renewable sources on a single dc bus.

In this study a double-port integration system for renewable energy sources is proposed. Figure 1 shows a small scale system of 1 kW PV array integrated together with a 1.5 kW wind generator (WG).

2.PROPOSED SYSTEM

This paper presents a micro-grid fed from wind and solar based renewable energy generating sources (REGS). DFIG is used for wind power conversion while crystalline solar photovoltaic (PV) panels are used to convert solar energy. The control of overall scheme, helps to provide quality power to its consumers for all conditions e.g. no-load, nonlinear load

and unbalanced loads. The controls of both generating sources, are equipped with MPPT. Emmanouil et al. [12] have proposed a droop based control system for micro-grid with the help of standalone battery converter. In the presented scheme, the droop characteristic is embedded in control of load side converter (LSC) of DFIG. This function varies the system frequency based on state of charge of the battery and slows down deep discharge and over-charge of the battery.

The DFIG in a proposed system, has also two voltage source converters (VSC). In addition to LSC, DFIG also has another VSC connected to rotor circuit termed as rotor side converter (RSC). The function of RSC is to achieve wind MPPT (W-MPPT). The solar PV system is connected to the DC bus through solar converter, which boosts the solar PV array voltage. With this configuration, the solar power can be evacuated in a cost effective way. This converter too is equipped with solar MPPT(S-MPPT) control strategy to extract maximum solar energy. In case of unavailability of wind energy source and lower state of charge of the battery, the battery bank can be charged through the grid power or a diesel generator through the same RSC. With the help of the LSC, rated frequency and voltage at the load terminals, are maintained under following conditions.

1. Varying amount of solar and wind powers.
2. Unavailability of solar power or wind power.
3. Loss of load or breakdown of the distribution system.
4. Different types of loads as unbalanced and nonlinear loads.

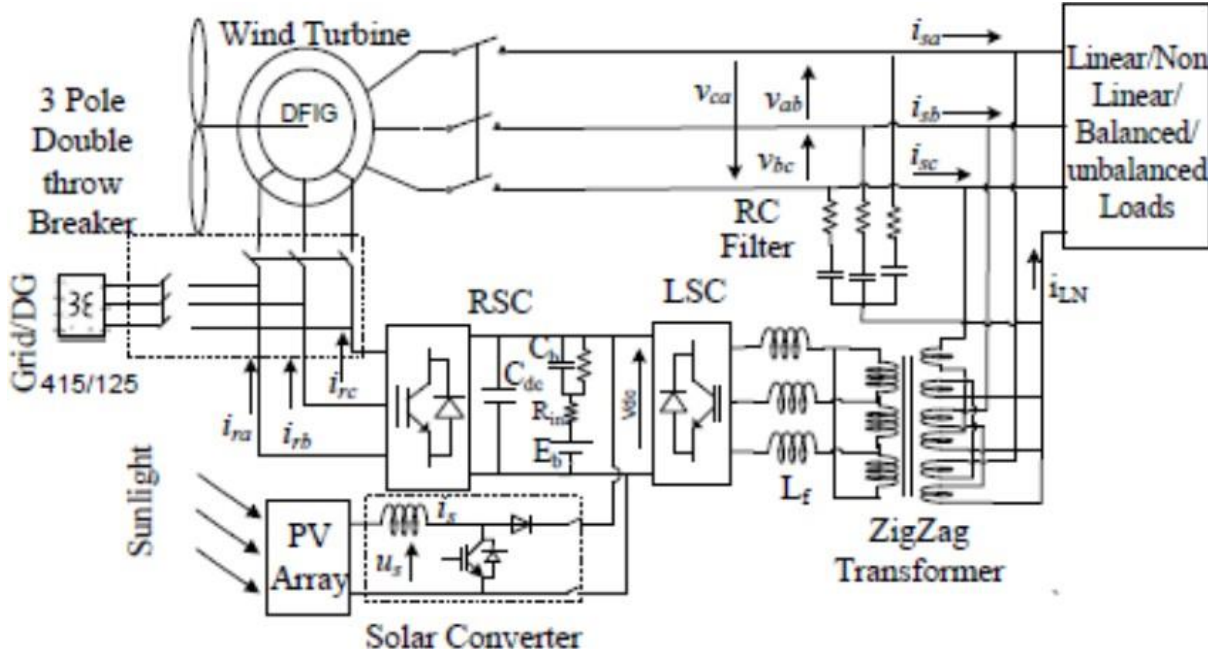

Fig. 1 BLOCK DIAGRAM

3. RESULTS

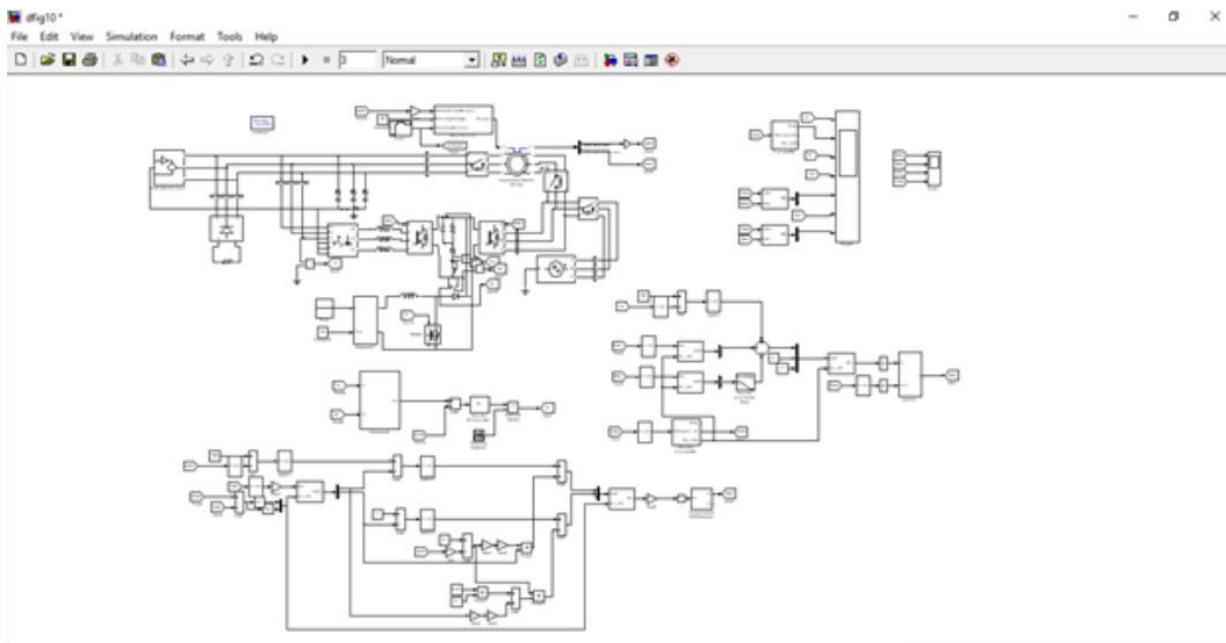

Fig. 2 Matlab Simulation

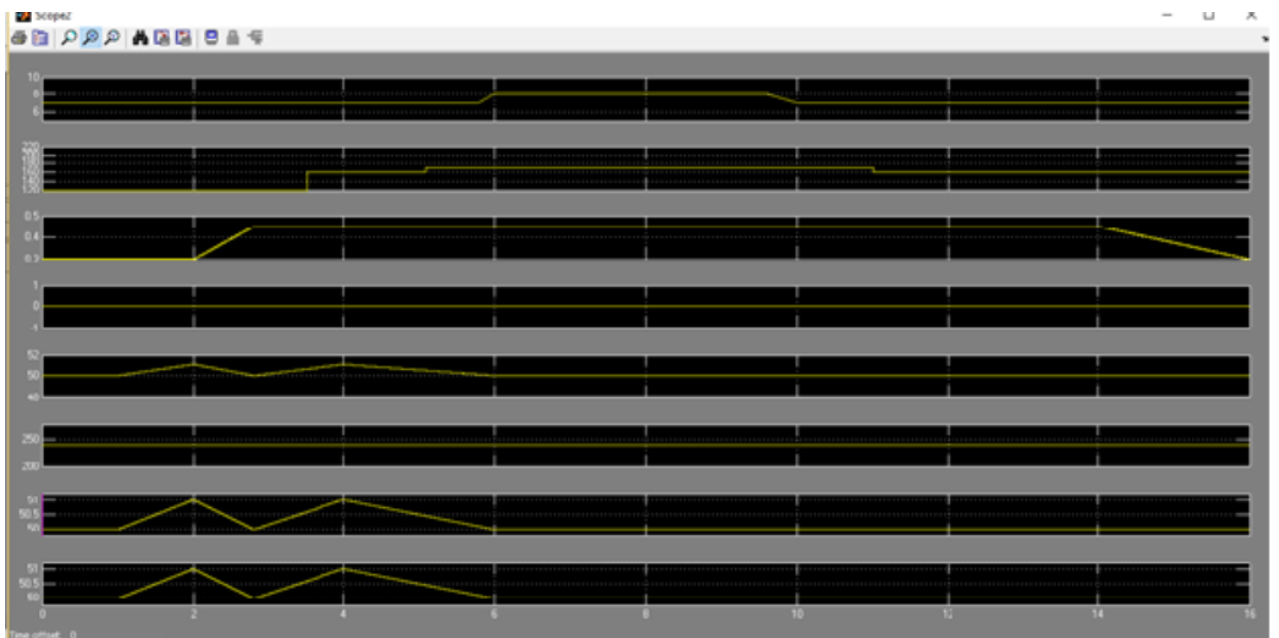

Fig. 3 Performance of REGS fed micro grid with wind energy source

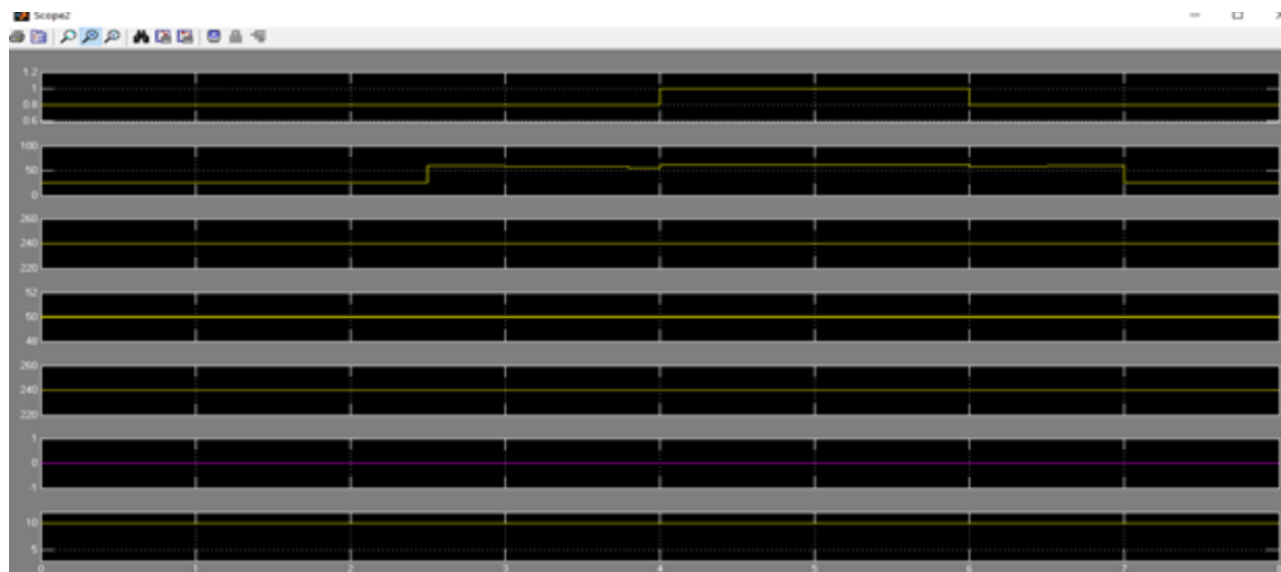

Fig. 4 Performance of the system without generating source and solar system is taken in the service

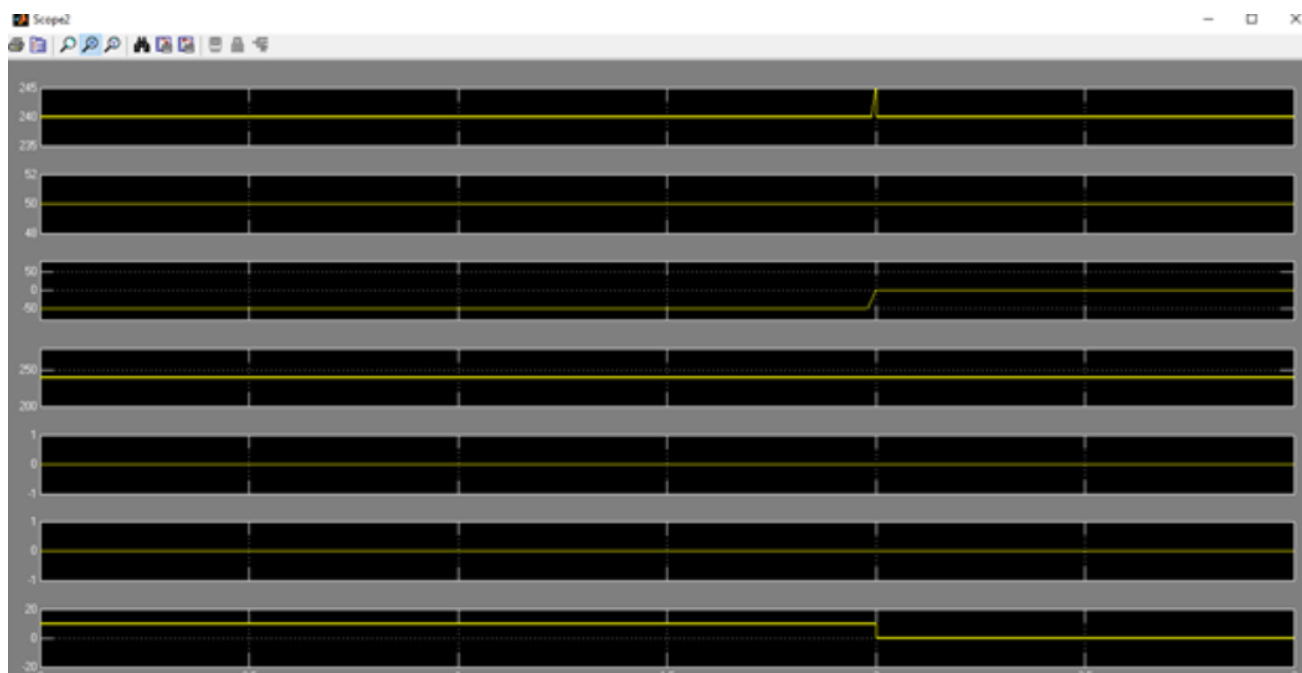

Fig.5 Performance of the system under loss of load at battery power

4.CONCLUSION

The proposed micro-grid system fed from REGS has been found suitable for meeting load

requirement of a remote isolated location comprising few households. REGS comprises of wind and solar energy blocks, which are designed to extract the maximum power from the renewable energy sources and at the same time, it provides quality power to the consumers. The system has been designed for complete automated operation. This work also presents the sizing of the major components. The performance of the system has been presented for change in input conditions for different type of load profiles. Under all the conditions, the power quality at the load terminals, remains within acceptable limit. The effectiveness of the system is also presented with test results with prototype in the laboratory. The system has also envisaged the external battery charging by utilizing the rotor side converter and its sensors for achieving rectifier operation at unity power factor.

5. REFERENCES

- [1] S.A. Papathanassiou, G.A. Vukas and M.P. Papadopoulos, USE OF POWER ELECTRONICS CONVERTERS IN WIND AND PHOTOVOLTAIC GENERATORS, Proceedings of IEEE International Symposium on Industrial Electronics, July, 1995
- [2] K.C Kalaistakis and G.J. Vachtsevanos, ON THE CONTROL AND STABILITY OF GRID CONNECTED PHOTOVOLTEAIC SOURCES, IEEE Transaction on Energy Conversion, Vol. EC-2, No. 4, Dec. 1987, pp. 556-562
- [3] F. Blaabjerg, Zhe Che and S.B. Kjaer, Power Electronics as Efficient Interface in Dispersed Power Generation Systems, IEEE Transaction on Power Electronics, Vol. 19, No. 5, Sept. 2004, pp. 1184-1194
- [4] J.M. Carrasco, L.G. Franquelo, J.T. Bialasiewicz, E. Galvan, R.C. Portillo Guisado, M.A. Partin Prats, J.I. Leon and M. Moreno- Alfonso, Power-Electronics Systems for Grid Integration of Renewable Energy Sources: A survey, IEEE Transaction on Industrial Electronics, Vol. 53, No. 4, Aug. 2006, pp. 1002-1016
- [5] Z. Liang, R. Guo. J. Li and A.Q. Huang, A High-Efficiency PV Module-Integrated DC/DC Converter for PV Energy Harvest in FREEDM Systems, IEEE Transaction on Power Electronics, Vol. 26, No. 3, March 2011, pp. 897-909
- [6] R. Bilinton and R. Karki, Capacity Expansion of Small Isolated Power Systems Using PV
Vol. 57, No. 1, 2023

and Wind Energy, IEEE Transaction on Power Systems, Vol. 16, No. 4, Nov. 2001, pp. 892-897.