

Multi- Stage power conversion with bi-directional power flow capability without using any storage elements.



R.Harsha Vardhan¹, R.Ramanjan Prasad², A.Naveen Kumar³

1.Assistant Professor , Malla Reddy Institute of Engineering & Technology,Maisammaguda,Hyderabad
 2.Assistant Professor , Vignana Institute of Technology & Science,Deshmukhi,Hyderabad, 3.Associate Professor , CVR College of Engineering

Abstract— This paper proposes the simulation of Multi-Stage power conversion with bi-directional power flow capability fed to Induction Motor. The conversion topology not only performs voltage transformation and electric isolation as the traditional power transformer does, but also provides additional features like facility to control the input current and power factor. Also, it makes the whole system smaller and compact and there is no need of installing any other protective relays for protection during faults .It simply works as a power quality conditioner.

Conversion of single phase ac to constant frequency adjustable magnitude ac with a high frequency transformer fed Induction Motor is introduced . In a switching strategy based on phase modulated converter is used in order to get soft switching when the output voltage and current are in the same quadrant. Single and three phase ac/ac converters with power conversion is based on fly back or push-pull topologies with multiple power conversion stages are proposed .Here we simulate conversion circuit using MATLAB/SIMULINK and we obtain various waveforms of input currents and output voltages which are quality sinusoidal waveforms and the input power factor is controllable.

Keywords— power electronics, multi stage power conversion,

INTRODUCTION

Traditional power transformer has been widely used in the power grid as the main equipment for the voltage conversion and isolation. The traditional power transformer has higher reliability and its technique is simple, but it has a big volume and heavy in weight. Transformer oil poses a threat to the environment, while the core saturation will

produce harmonics, which results in a large inrush current. With the nonlinear load, the distorted current flows into the grid through the transformer coupling, causing harmonic pollution. A disturbance of the power supply side voltage is delivered to the load side, resulting in the voltage flicker, even leading to an impact on the sensitive load.

With the development of power electronics, the multistage conversion (MSC), as a new type transformer of voltage conversion and energy delivery, is gaining more and more attention. It uses power electronic devices and power electronic technology to convert the energy in the distribution system and extend the functions of the conventional power transformer. Besides the voltage transformation and the electric isolation, at the same time, it presents many additional features. The input current and power factor are controllable, and the high-frequency transformer makes the whole system smaller and lighter. And also the MSC can offer the customers power supply with the particular voltage level and the particular frequency without requiring additional power transformer and frequency conversion equipment. The power electronics can shut down the fault current without any other protective relay devices[1].

The advances in power semiconductor device technology, low-cost, high-speed control processors, and matured PWM algorithms have led to a number of modern power converter topologies. A new type of transformers based on Power Electronics (PE) has been introduced, which realizes voltage transformation, galvanic isolation, and power quality enhancements in a single device. The PE based transformer provides a fundamentally different and more complete approach in transformer design by using power electronics on the primary and secondary sides of the transformer. Several integrated PQ features such as instantaneous voltage regulation under load dynamics and transients, voltage sag compensation, power factor correction, and harmonic suppression can be incorporated into PET, thanks to the application of power electronics technology[2].

For realizing the PET, different topologies in literature have been presented. In the AC/AC buck converter has been proposed to transform the voltage level directly and without any isolation transformer. This method is perhaps the most direct approach to single phase AC power conversion, but, it would cause the semiconductor devices to bear very high stress[3].

Another approach is a three-part design that utilizes an input stage, an isolation stage, and an output stage. These approaches enhance the flexibility and functionality of the electronic transformers owing to the available DC links. In for operating properly in medium voltage levels, the series to parallel connection of converters has been used.

CONSTRUCTION OF MSC CIRCUIT

The MSC was composed of the primary side converter and the secondary side converter, with the high-frequency transformer. The input AC voltage was modulated into the high-frequency square waveform by the primary side converter, and then coupled to the secondary side.

The high-frequency square waveform of the secondary side was converted into the waveform required by secondary side converter. Its implementation can be classified into two major approaches: one is AC-AC-AC conversion without the dc-link, the other is AC-DC-AC-DC-AC conversion with the dc-link, and the latter is shown in Fig. 1.

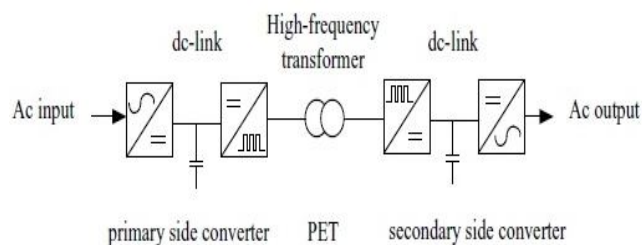

Fig. 1. Principle diagram of PET.

The structure of AC-DC-AC-DC-AC converter is more complex than the AC-AC-AC converter, however, better in the control characteristics. The input current and the output voltage can be controlled by the PWM modulation. Typical AC-DC-AC-DC-AC topology is shown.

For the application to the distribution system, the input stage of the proposed PET uses three-phase three-level PWM rectifier, the isolation stage employs three-level half-bridge converter with the high-frequency transformer, while the output stage uses three-phase two-level inverter. In a

high-voltage large-capacity system, three-level rectifier can reduce the stress rating of components and improve the efficiency. Because of the three-level circuit, its dv/dt can be stepped down by half, and the output voltage harmonics will be reduced, either. So the three-level rectifier, which is helpful to the realization of the sinusoidal output voltage, is more suitable for the large-capacity high-voltage power electronic conversion system. Because of the low voltage, using two-level circuit in the output stage can meet the requirements[4].

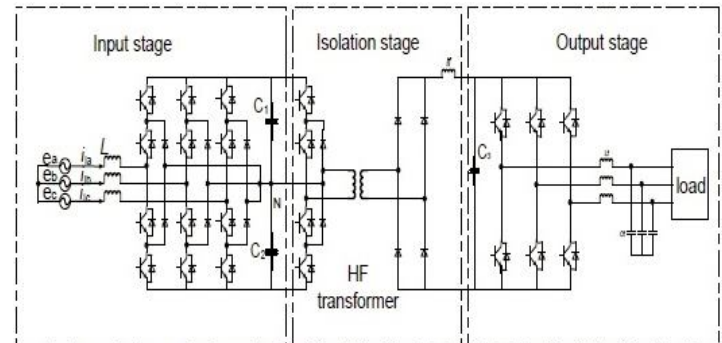

Fig. 3. Proposed topology of PET in the distribution system.

CONTROL STRATEGY

In PET in distribution system there are three stages involved and they are known as follows

1. Control Strategy of Input Stage
2. Control Strategy of Isolation Stage
3. Control Strategy of Output Stage

The above three stages are discussed and also there requirement in PET, to obtain more efficient operation or PET.

1. Control Strategy of Input Stage

The PET not only provides the customer constant and sinusoidal waveform voltage, but also should try to reduce the harmonics of the input current and avoid the harmonic pollution into the grid. The reactive power and high-voltage dc-link voltage closed-loop controls provide the ability to adjust the reactive power and stabilize the dc-link voltage of the high-voltage DC side, which will ensure the input current of PET sinusoidal and the controlled power factor[5].

To achieve the above functions, in the outer-loop control, the feedback DC voltage is compared to the reference value, the difference is passed through the PI controlled to get the reference value of d-axis current. When the reference value of q-axis current is set to zero, the rectifier can achieve unity power factor operation.

In the inner-loop, three-phase input currents are transformed into d-axis current and q-axis current components in the synchronous rotating d-q reference frame, respectively, which are compared with the reference values of both d-axis current and q-axis current, their differences are then formed the modulated wave signal by the PI controller [6]. The three-level rectifier control principle is shown in Fig. 4.

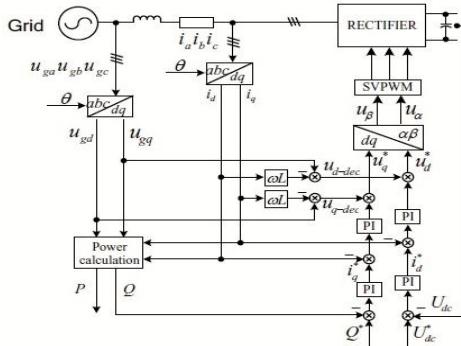

Fig. 4. Control principle diagram of grid-side converter.

2. Control Strategy of Isolation Stage

The dc voltage from the input stage is modulated into the high-frequency square wave by the three-level half-bridge inverter of the isolation stage. Then the square wave is transformed into the stable dc low voltage by the high-frequency transformer and uncontrollable diode rectifier. Four switches of three-level half-bridge are controlled to modulate the high-DC link voltage into the high-frequency square wave. Here, the high-frequency transformer isolates the primary-side converter and the secondary-side converter and finish voltage conversion. Considering unidirectional power flow, this paper uses uncontrollable diode rectifier, which is shown in Fig. 3. The high-frequency square wave of the secondary-side is passed through the diode rectifier to obtain the low-DC link voltage on the capacitor. With the certain amplitude of DC link high voltage and the certain ratio of transformation, the DC link low voltage will obtain the corresponding values with the different duty cycles of the high-frequency square wave. Therefore, the isolation stage employs the low-voltage dc-link voltage closed-loop control to maintain the constant DC link low voltage[7].

3. Control Strategy of Output Stage

In the output stage, three-phase two-level inverter outputs the constant-amplitude and constant-frequency voltage to the load through the output voltage closed-loop control. When the load changes within a certain range, the PET should maintain the amplitude of output voltage. The control

principle diagram is shown in Fig. 6, three-phase output voltages are converted to the d-axis U_d and q-axis U_q in the synchronous rotating d-q reference frame, respectively, compared with the reference values of U_d^* U_q^* . The modulated signal was formed by the PI controller. The SVPWM control algorithms realize the control of inverter switches

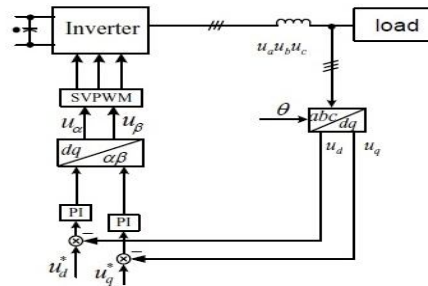
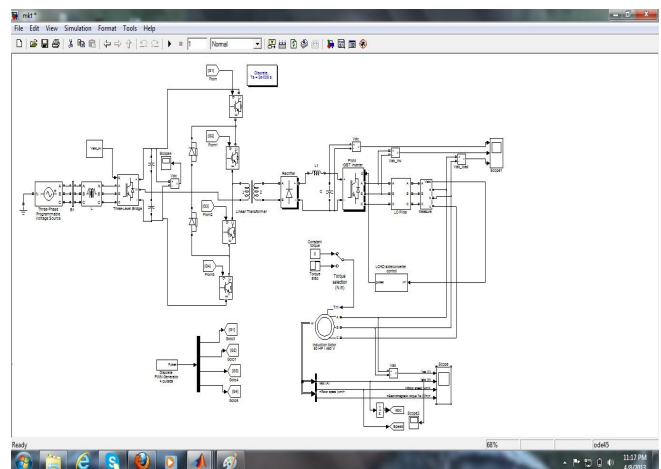

Fig. 6. Control principle diagram of load-side inverter.

SIMULATION

The PET model is established in Matlab/Simulink, as shown in Fig. The model parameters are as follows: ① grid side: line-line voltage 10 kV, filter inductance 100 mH. ② DC link High-voltage side: capacitor 6800 μ F, the reference value of DC voltage is 15 kV, ③ High-frequency transformer: ratio of transformation is 10:1, frequency 10 kHz, ④ DC link low-voltage side: filter inductance 10 mH, filter capacitance 1200 μ F, the reference value of DC voltage is 600 V, ⑤ Load side: filter inductance 1 mH, filter capacitance 33 μ F, the reference value of load-line voltage is 380 V, load as induction motor. A closed loop control is provided.

Three-level half-bridge inverter modulates the DC high voltage into the high-frequency square wave with constant duty cycle.. The high-frequency square wave of secondary side is also shown.



Block Diagram of MSC in MATLAB/ SIMULINK.

Simulation is done for the above block of Power Electronic Transformer using MATLAB/SIMULINK. As discussed in the above paragraphs of Simulation of Power Electronics the blocks and the required technique are provided with using space vector modulation and PWM technique which are used for the controlling of triggering and pulses and here in this we are using an induction motor as a load and we are simulating the circuit for the required technique and pure sinusoidal with reduced harmonics content in the wave form[8].

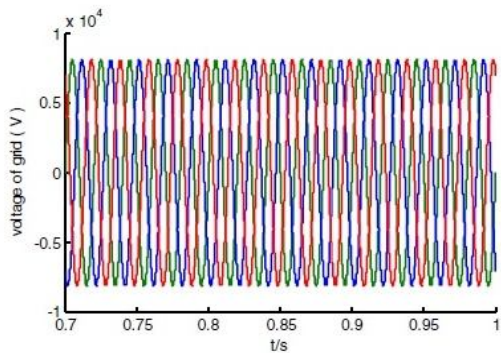

(a) grid voltage

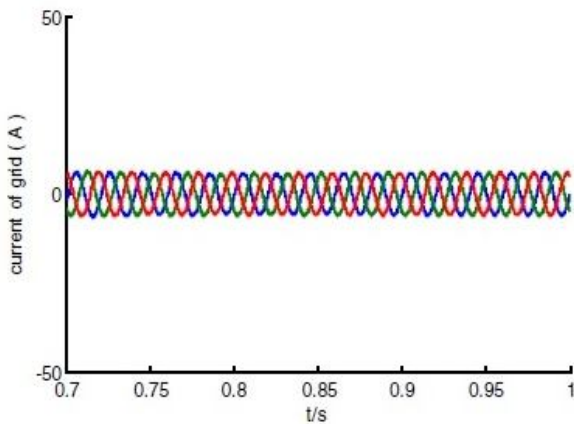

(b) grid current

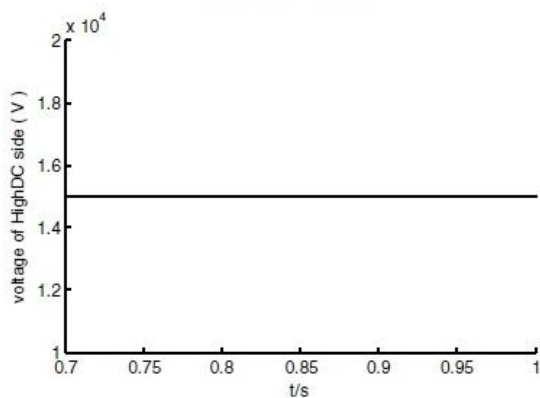

(c) voltage in high-DC side

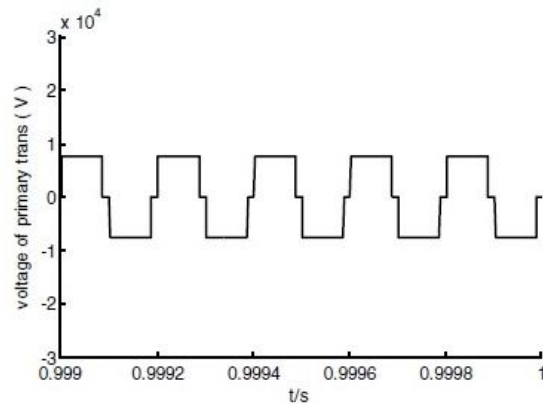

(e) primary voltage of high frequency transformer

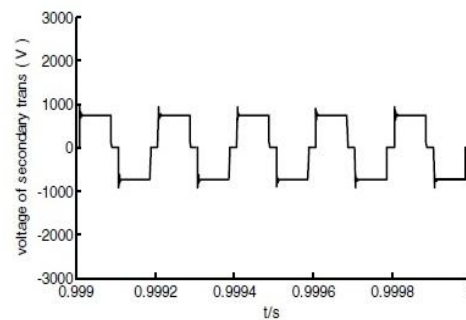

(f) secondary voltage of high frequency transformer

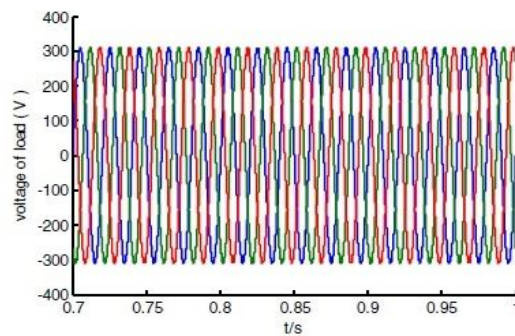

(h) load voltage

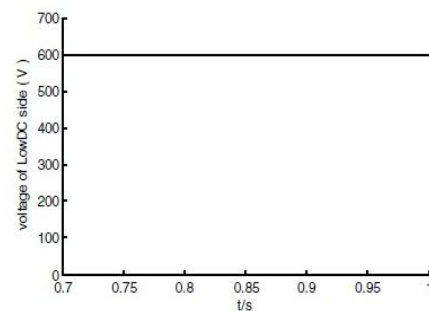

(g) voltage in low-DC side

SIMULATION RESULTS

We obtain the simulation results of power electronic transformer with induction motor as load as below. We can clearly observe that the current waveforms are purely sinusoidal after a transient period of 0.2 seconds. Hence we obtain the waveforms as below:

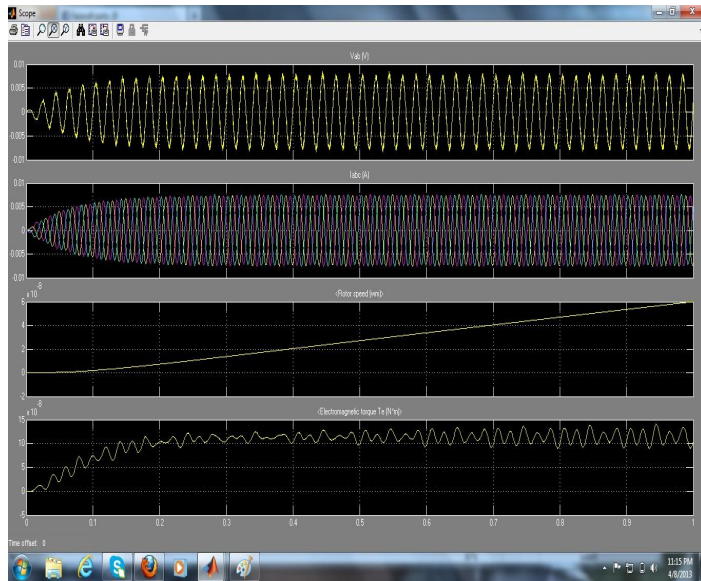

FIGURE OUTPUT WAVEFORMS WITHOUT CONTROL TECHNIQUES

The above result represents the wave form of Vab [V], Iab[A], Speed, Torque Induction motor without controlling.

Actual result at load side with same Vab, Iab, Speed, Torque of Induction motor with controlling is as below.

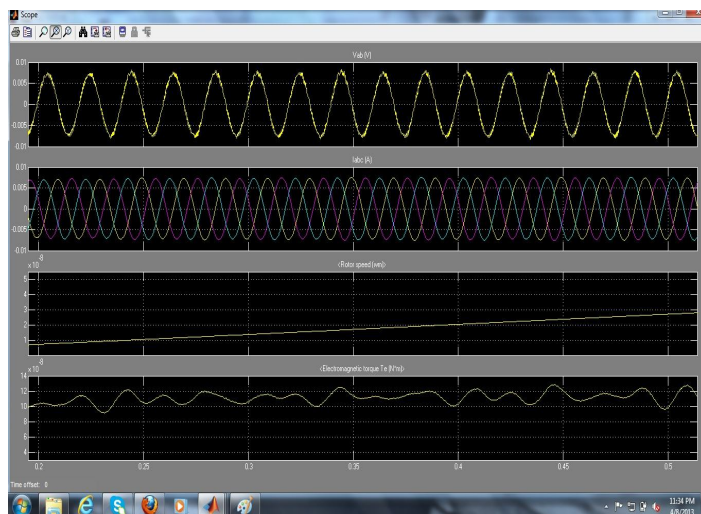

FIGURE OUTPUT WAVEFORMS WITH CONTROL TECHNIQUES

The above result represents the wave form of Vab [V], Iab[A], Speed, Torque of Induction motor with controlling. Hence we obtain the waveforms as above.

APPLICATIONS

APPLICATION IN HARVESTING OF ENERGY FROM RENEWABLE ENERGY SOURCES

One of the most important applications of PET is in harvesting of energy from renewable energy sources. Here a particular application is presented in details. This application is related to the generation of electric power from wind. In the vertical wind mills as shown in Fig 1.2, the induction generator is located in a nacelle at the top of a tower of height 80 to 100 meter[8].

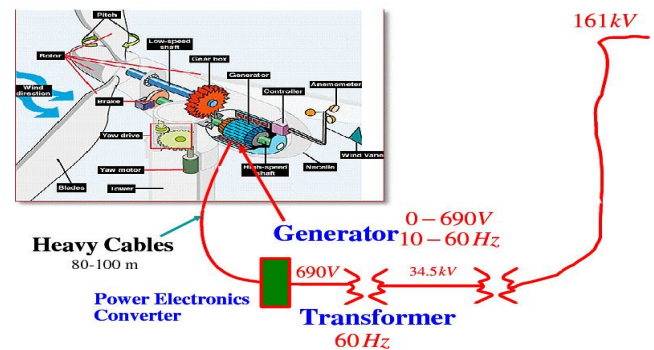

Wind power application

In most of the 1 MW wind mills the induction generator operates at a voltage of 690 volts. The power flows from the top of the tower at a very high current (of the order of 1.5 K A) to the bottom where the required power converters are located to convert the variable frequency ac to a 60 Hz ac and connect to the collection grid of the wind farm at a voltage level of 34.5 KV through a heavy line frequency power transformer. This transformer weighs a few tons. The power flowing from the top to the bottom of the tower at high current encounters considerable amount of ohmic loss. The heavy long copper cable also adds to the cost. One solution to avoid this loss is to put the power transformer and the power electronic converters at the top in the nacelle.

APPLICATION IN TRACTION

In the early days of electric railways, DC was the most common power supply. As it was at the time not feasible to step down DC voltages onboard the train, transmission between the substation and the train had to be at a low voltage (between 750 V and 3,000 V) so that it could be fed directly to the traction motors. The disadvantage of the low voltage was that it caused high conduction losses in the overhead line. Later, single-phase AC electrification Using higher voltages was introduced (15 kV / 16.7 Hz and 25 kV / 50 Hz), reducing transmission losses. The penalty, however, was the large and heavy transformers that had to be carried on the train[9].

CONCLUSION

This paper proposes the simulation of Multi- Stage power conversion with bi-directional power flow capability topology. The input stage three-phase three-level PWM rectifier reduces the voltage stress rating of components. The isolation stage employs the low-voltage dc-link voltage closed-loop control with a high-frequency step-down transformer to maintain the constant dc low voltage[10]. The output stage three-phase two-level inverter outputs the desired voltage and power to the load. The simulation results and the experimental results show that the input currents and the output voltages have quality waveforms, and verify the proposed power electronic transformer system.

FUTURE SCOPE

The Multistage Conversion topology applied to power system as described above can also be further implemented in traction and can also be effectively used with renewable energy sources. Further advantages if used in traction include Improved energy efficiency from AC input to

DC output from 88 to 90 percent to more than 95 percent , Reduced EMC and harmonics, Lower acoustic emissions

References

1. A Power Electronic Based Transformer for Feeding Sensitive Loads H. Iman-Eini¹, J.L. Schanen², Sh. Farhangi¹, J. Barbaroux², JP. Keradec² 1: School of Electrical and Computer Engineering, University of

Tehran, Tehran, Iran 2: G2ELab, ENSIEG B.P.46, 38402 St Martin d'Heres cedex, France.

2. Power Electronic Transformer based Three-Phase PWM AC Drives by Professor Ned Mohan.
3. Modelling and Characterization of Power Electronics Converters Using Matlab Tools.
4. Huang Yi-yu, Mao Cheng-xiong, Lu Ji-ming, Fan Shu. Study on control strategy for power electronic transformer in power system. *Relay*, 2004, 32(6): 35-39.
5. Mao Cheng-xiong, Fan shu, Wang Dan. Theory of Power Electronic Transformer and Its Applications. *High Voltage Engineering*, 2003, 29(10): 4-6.
6. Mao Cheng-xiong, Fan shu, Huang Yi-yu. Theory of Power Electronic Transformer and its Applications Part 2 Applications and Control. *High Voltage Engineering*, 2003, 29(12): 1-3.
7. Zhao Jian-feng. Simulation study of a power electronics transformer with constant output voltage. *Automation of Electric Power System*, 2003, 27(18): 30-33, 46.
8. Deng Wei-hua, Zhang Bo, Hu Zong-bo. Research on the topology and control scheme of power electronic transformer. *Automation of Electric Power System*, 2003, 27(20): 40-44,48.
9. Cheng Jian-peng, Mao Cheng-xiong, Fanshu, et al. Principle of electronic power transformer and its simulation study. *Electric Power Automation Equipment*, 2004, 12(24): 23-26.
10. Cui Yan-yan, Mao Cheng-xiong, Lu Ji-ming, et al. Voltage and reactive power synthetic optimization in the distribution system based on electronic power transformer. *Relay*, 2006, 34(6): 24-28, 43.