

IoT Based Electrical Devices Surveillance Control

R Harsha Vardhan^{1*}, R Ramanjan Prasad², Dr.B Pakkiraiah³ M. Rajitha⁴

¹Department of EEE, CVR College of Engineering, Hyderabad, India

²Department of EEE, Vignan Institute of Technology and Science, Yadadri-Bhuvanagiri, India

³Department of EEE, Gokaraju Rangaraju Institute of Engineering and Technology, Hyderabad, India

⁴Department of EEE, CVR College of Engineering, Hyderabad, India

Abstract. Analogue electronics devices are losing ground to digital electronics components in today's technologically evolved society. Another aspect of our increasingly digital society is the home device control system. A lot of people are chatting it up over the cellular phone network. These phone networks rely on WIFI modules as their foundation. A shorthand way to say "global system of mobile communication" is WIFI. In addition to being widely employed in industry, it is also used in several electronics projects undertaken by engineering students. It is possible to operate equipment from afar using WIFI-based projects. For instance, what if you wanted to be able to operate any equipment from afar using only your cell phone? Would it be possible? Sure, I can help you with that. Wi-Fi modules and cell phones make it easy to power on and off various gadgets. The home devices control system was developed to enable the control of home equipment from a mobile phone by using the aforementioned ideas. This document makes use of a regulated 5V, 1A power source. When controlling voltage, a 7805 three-terminal regulator is ideal. When a 230/12V step-down transformer's secondary AC output needs rectifying, a bridge-type full wave rectifier is the way to go.

1 Introduction

The pathway from power supplier to end user is the primary focus of our article. It used to be standard practice for the power board to dispatch workers to the customer side at the end of each instant to take metre readings. Typically, these workers are hired on a contract basis or are supplied by subordinate authorities on a contract basis exclusively. Because conflicts between authorities might lead to data loss, this task can quickly become tedious and difficult to do. [1] The final bills are produced and distributed to the consumers when the data obtained by the staff is relayed to the power board. This overall method is successful, but it might need some tweaks since it's expensive, time-consuming, and a pain to do. Additionally, due to different geographical and atmospheric circumstances, there are several locations that are difficult for personnel to access. [2]

Research and development of smart electrical energy metre technology has been ongoing for almost a decade. A number of methods for quantifying power use have been developed.

*Corresponding author: 83.harsha@gmail.com

After consumers create and deliver energy via one of various ways, the energy board will send them a bill. For instance, most Malaysian homes still utilise antiquated with electromechanical watt metres that do not include any kind of automation in their readings. the third users will be need to wait for their monthly energy bill in order to pay for their energy use. In a typical month, a member of the metre board billing staff will visit each residence to collect metre readings and deliver bills simultaneously. Electricity metres, often called energy metres, are devices that track how much power a home or company uses. The two most common kinds of metres used by domestic ordinary power consumers are three-phase and single-phase. The kilowatt-hour (kWh) metre is used by all electrical services to monitor energy use. Afterwards, electronic metres were produced, which the electro-mechanical ones but used a digital system instead of an analogue one. Users may record the time and date of energy use in addition to voltage, power reading unit, current, and more using this system. [4]

Thanks to globalisation, India is becoming a major market for many nations. Because of the rise in industry, the demand for power has skyrocketed. India is now experiencing a massive power outage. The electrical system has made significant progress in the previous forty years of planning, but it still isn't enough to meet demand. This means the nation has been dealing with a power outage for quite some time. Power outages are making already unpleasant summers in India's capital and other cities even worse, as temperatures continue to rise. Our country's businesses and economy are feeling the effects of the power outage. Because they are unable to utilise the electrical equipment that are essential to their daily lives, customers find no solace in power shortages and outages. The majority of people's electrical loads come from necessities like cell phones, fans, lighting, and the like. [5]

2 Literature Survey

The current setup here is to manage electrical equipment in the business sector by means of a remote control system that operates on radio frequency. By using a radio frequency (RF) based wireless remote-control system, it is possible to turn on or off electrical equipment from anywhere in the home or business, even when there is no direct line of sight. The controlling circuit is composed of a few passive components, an HT12E encoder and decoder, and an RF transmitter and receiver module that operate at 434 MHz. For the decoder, a relay links the four output channels to the appliances, and for the encoder, those same channels act as input switches. The circuit operates on 9 V and uses an amplitude shift keying (ASK) gearbox mechanism. Using radio frequency technology, this project aims to build a circuit that can operate in the absence of direct line of sight and does not need programming skills. [6]

3 Proposed System

Analogue electronics devices are losing ground to digital electronics components in today's technologically evolved society. Another aspect of our increasingly digital society is the home device control system. A lot of people are chatting it up over the cellular phone network. These phone networks rely on WIFI modules as their foundation. A shorthand way to say "global system of mobile communication" is WIFI. In addition to being widely employed in industry, it is also used in several electronics projects undertaken by engineering students. Projects that rely on WIFI allow users to remotely operate gadgets using mobile devices. [7] is cited. For instance, what if you wanted to be able to operate any equipment

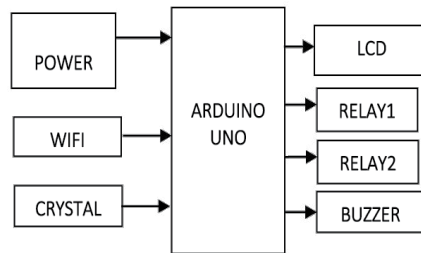

Figure 1 Block Diagram of the proposed system

from afar using only your cell phone? Would it be possible? Sure, this article can help you with that. Wi-Fi modules and cell phones make it easy to power on and off various gadgets. The home devices control system was developed to enable the control of home equipment from a mobile phone by using the afore-mentioned ideas. [8] the block diagram of the suggested system shown in figure 1.

4 Wi-Fi module

4.1 Global System for Mobile Communication

WIFI, which stands for Global System for Mobile communications, reigns (important) as the world's most widely used cell phone technology. Cell phones use a cell phone service carrier's WIFI network. WIFI, short for "Global System for Mobile communications," is the de facto standard for mobile phone networks worldwide. By identifying and connecting to nearby cell phone towers, mobile phones are able to access the WIFI network provided by cellular service providers. Wireless cellular data transmission using the World Wide Web Protocol (Wi-Fi) is a universally recognized technology. In 1982, a group of experts came together under the acronym WIFI to establish a standard for mobile phones in Europe. Their goal was to develop requirements for a 900 MHz mobile cellular radio system that could be used throughout the continent. Many nations outside of Europe are expected to become WIFI partners.

4.2 Modem Specifications

The WIFI modem shown in figure 2 is SIM300 which is plug-and-play tri-band WiFi module for the suggested system. The SIM300 is a small and power-efficient module that supports voice, text, data, and fax via WIFI/GPRS900/1800/1900Mhz. It also has an industry-standard interface. The SIM300's top characteristics allow it to work with an almost infinite variety of applications, including WLL (Fixed Cellular Terminal) applications, M2M apps, portable devices, and many more. 40x33x2.85 mm tri-band WIFI/GPRS module Support for customized MMI and keypad/LCD technologies.

5 Description

5.1 Mobile Station

The mobile station (MS) comprises of the radio handset, show, and computerized signal processors, while the SIM is a brilliant card. With the SIM, a client's very own versatility is

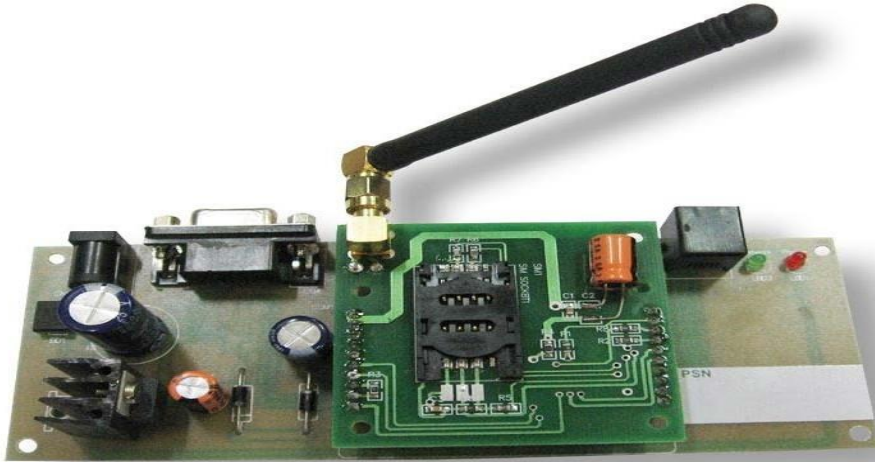

Figure 2 Wi-Fi modem

guaranteed, permitting them to get to all membership benefits no matter what the terminal's area or use. A user may access their subscription services, make and receive calls on another WIFI cellular phone, or both only by putting the SIM card into another phone. International Mobile Equipment Identity (IMEI) is a framework that interestingly recognizes cell phones. A International Mobile Subscriber Identity (IMSI) is put away on the SIM card notwithstanding the endorser's very own subtleties and a confirming mystery key. The autonomy of the IMEI and the IMSI considers the opportunity of portability of people. The SIM card might be safeguarded with a PIN or secret word to forestall unapproved use.

5.2 Base Station Subsystem

The Base Station Controller (BSC) and the Base Transceiver Station (BTS) make up the Base Station Subsystem. Like the rest of the system, they are able to work with components from various manufacturers because of the defined Abis interface that they communicate over. The Base Handset Station houses the radio handsets of a cell and is responsible for the conventions that interface the Portable Station to the radio organization. It is possible to install a huge number of BTSs in a broad metropolitan area. For a BTS to be considered, it must be affordable, dependable, portable, and tough. The Base Station Regulator is accountable for the radio assets of at least one Base Stations (BTSs). Then, at that point, it deals with setting up radio channels, bouncing frequencies, and taking care of handoffs. The versatile assistance exchanging focus (MSC) is associated with the cell phone through the BSC. In addition to its primary purpose, the BSC may change the voice channel from 13 kbps on the radio connection to the standard 64 kbps on ISDN.

5.3 Network Subsystem

Mobile services switching centers (MSCs) are the central processing units (CPUs) of a network. It handles everything needed to manage mobile subscribers, such as authentication, location updates, handovers, and routing calls to subscribers who are traveling. A standard PSTN or ISDN switching node is another one of its uses. The Network Subsystem is the collective name for the several functional units that work together to offer these services. The

ISDN utilizes the ITUT Flagging Framework Number 7 (SS7), which is generally used in current public organizations, and the MSC gives the association with the public fixed network for motioning between utilitarian units.

To guarantee proper call routing and the potential worldwide transit of WIFI, the MSC collaborates with the Home Location Register (HLR) and the Visitor Location Register (VLR). For every WIFI network, the HLR stores all the subscriber's administrative data, including the GPS location of their mobile device. Versatile Station Meandering Numbers are standard ISDN numbers that are utilized to course calls to the portable station where the versatile is genuinely found. Despite its potential implementation as a distributed database, conceptually, each WIFI network has one HLR.

The Visitor Location Register keeps track of certain administrative data retrieved from the HLR for each mobile device currently under the authority of the VLR. This information is vital for call the board and the arrangement of membership administrations. Most producers of exchanging hardware utilize one VLR in mix with one MSC, notwithstanding how each useful element might be carried out autonomously. Since the MSC and VLR both handle the same geographical area, signaling may be simplified in this manner. The location records, and not the MSC, include information on individual mobile stations.

The other two registries primarily serve to authenticate and ensure security. The EIR is a database that records all authorized mobile devices on the network. It does this by utilizing the Global Portable Hardware Character (IMEI) to distinguish explicit versatile stations. An IMEI becomes invalid when it has been accounted for taken or isn't type approved. The Validation Place keeps a copy of the mystery key kept on the SIM card of each and every endorser to confirm their character and scramble the radio channel. All database information is protected.

5.4 Base Station Subsystem (BSS)

The BSS is made up of two sections: a. The BTS, or Base Transceiver Station, b. The computer that controls the base station. By exchanging data over the designated Abis interface, the BTS and the BSC can facilitate operations involving components manufactured by several vendors. Four, seven, or even nine cells might make up a BSS's radio components. It is possible for a BSS to have many base stations. The BSS uses the Abis interface for correspondence with the BTS and BSC. The next step is to establish a dedicated high-speed connection (T1 or E1) between the BSS and the Mobile MSC. The connection between the BSS and MSC is shown in figure 3.

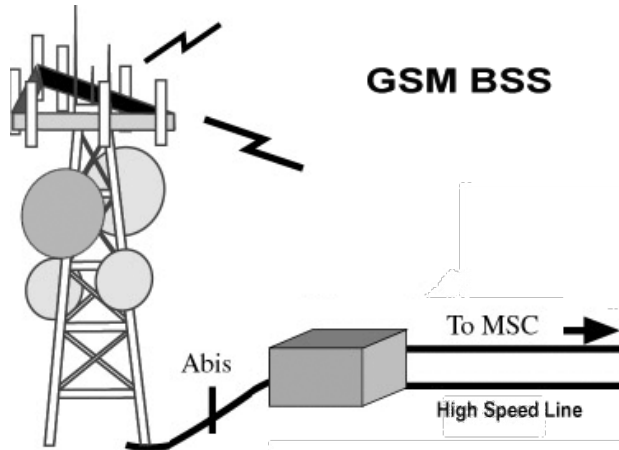

Figure 3 BSS and the Mobile MSC

5.5 The Base Transceiver Station (BTS)

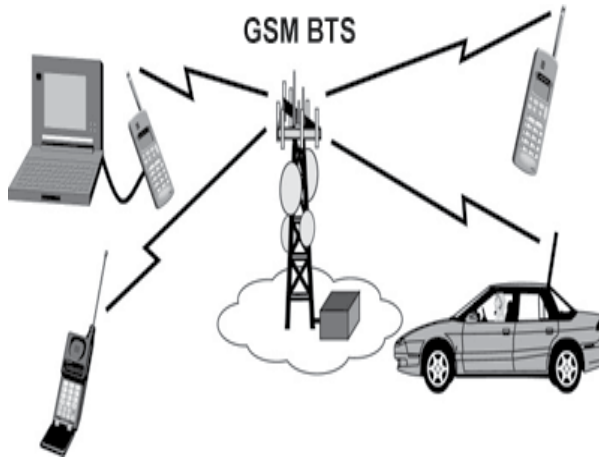

Figure 4 BTS connection View

The base station transceiver subsystem (BTS) which is shown in figure 4 houses the radio transceivers that control the protocols for radio connections with the MS and identify a cell. It is possible to install a huge number of BTSs in a broad metropolitan area. Each network cell's transceivers and antennas are represented by the BTS. The typical location for a BTS in a cell is in the middle. The dimensions of a cell are defined by its transmitting power. The quantity of handsets in a BTS goes from one to sixteen, contingent upon the client thickness in the cell. All BTSs are relegated to specific cells. Works like encoding, decoding, multiplexing, regulating, and taking care of RF signs to the receiving wire are additionally essential for it. Different capabilities incorporate transcoding, rate variation, time and recurrence synchronization, voice through full-or half-rate administrations, irregular access identification, timing advances, and uplink channel estimations. [9]

5.6 The Base Station Controller (BSC)

At least one BTSs' radio assets are administered by the BSC. Arrangement of radio channels, recurrence jumping, and handovers are completely taken care of by it. For the versatile to speak with the MSC, the BSC should be available. Also, the BSC changes over the radio connection's 13 kbps voice channel to the 64-kbps standard channel utilized by PSDN or ISDN. Schedule openings and frequencies are appointed and delivered by it for the MS. Intercell handover is likewise overseen by the BSC. It directs the BSS and MS power transmission under its locale. The BSC's responsibility is to split the accessible time allotments between the MSC and the BTS. It deals with radio assets and capabilities as an exchanging gadget. Among its different capacities, it has attributes like as the executives of recurrence bouncing, utilizing traffic focus to eliminate MSC line counts, Interfacing the BSS's Tasks and Upkeep Center Exchanging frequencies between BTSs, The synchronization of time and recurrence Power the board, Time-postpone estimations of gotten signals from the MS.

5.7 Relay

A switch that is powered by electricity is called a relay. While different working principles are also used by relays, most of them employ an electromagnet to power their switching mechanisms and schematic view of the relay shown by figure 5. At the point when a low-power signal is expected to control a circuit or when a few circuits should be constrained by a solitary sign, transfers are utilized. The first reason for transfers was to copy and retransmit signals over significant distance broadcast associations. The consistent capabilities performed by transfers were generally utilized in early PCs and phone trades. Contractors are an exceptional sort of hand-off that can deal with the monstrous measures of power expected to drive an electric engine straightforwardly. A semiconductor device that is activated by light is used to operate power circuits in solid-state relays, which eliminate the need for moving components. Computerized gadgets alluded to as "security transfers" in the present electric power frameworks complete similar obligations as their simple ancestors, which included aligned working attributes and, at times, various working curls, to protect electrical circuits against over-burden or blunders.

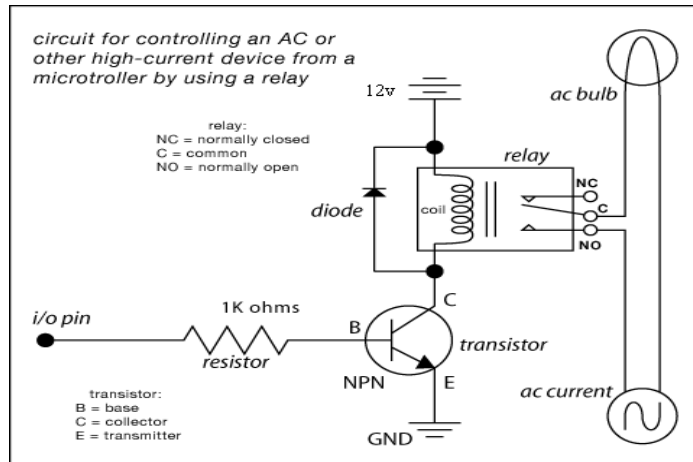

Figure 5 Schematic diagram of Relay

6 Arduino Uno

With their single-board micro controllers and micro controller kits, the open-source hardware and software business, project, and user community known as Arduino creates digital gadgets and interactive things with physical and digital sensing and control capabilities. The General Public License (GPL) and the Lesser General Public License (LGPL) are used to license its goods, which means that anybody may make Arduino boards and distribute the software. You may get Arduino boards in two different forms like preassembled and as DIY kits.

The designs of Arduino boards make use of a wide range of controllers and microprocessors. Figure 6 shows the front view of the Arduino Uno and figure 7 shows the Back side view. The boards are associate with different circuits and development circuits utilizing the computerized and simple I/O pins that accompany them. A few sorts of boards have sequential communications interfaces, like All Universal Serial Bus (USB), which might be utilized for programming from PCs. The microcontrollers are typically coded utilizing a blend of C and C++ highlights. The Arduino project offers an IDE based on top of the Handling language project, notwithstanding the standard compiler toolchains. In 2003, students at Italy's Interaction Design Institute Ivrea launched the Arduino project with the goal of giving anybody, from complete beginners to seasoned pros, a simple and inexpensive means to build devices that can sense and respond to their surroundings. Common examples of gadgets like this aimed at novice hobbyists include basic thermostats, motion detectors, and robots. The name Arduino is gotten from a bar in Ivrea, Italy, where a couple of the undertaking's organizers would assemble. The bar was called after Arduin of Ivrea, who filled in as both lord of Italy from 1002 to 1014 and margrave of the Walk of Ivrea.



Figure 6 Front view of the Arduino Uno

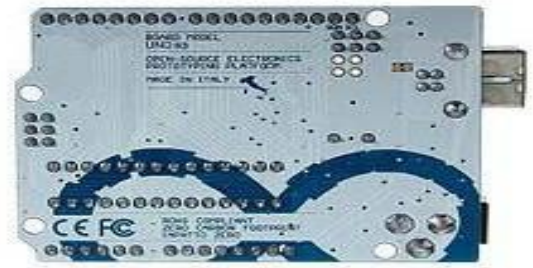

Figure 7 Back side of module

7 PIN Capability

The Arduino is open-source software and we can also get the equipment reference plans on the Arduino site; they're given under an Innovative Hall Attribution Offer The same 2.5 permit. You may likewise get creation and design documents for specific equipment variations here. The makers have asked that the name Arduino stay remarkable to the first item and not utilized for subordinate items without consent, regardless of whether the product and equipment plans are openly available under copyleft licenses. In the authority strategy proclamation on the utilization of the Arduino name, it is focused on that the undertaking will incorporate work from others into the last conveyance. A number of commercially available Arduino-compatible devices have used names that finish in -Arduino to sidestep the project name.

The 8-bit AVR microcontrollers used on most Arduino boards are manufactured by Atmel. These microcontrollers come in a variety of models, each with its own set of features, pinout, and flash memory capacity (ATmega8,[24] ATmega168, ATmega328, ATmega1280, ATmega2560). Atmel introduced the 32-bit Arduino Due in 2012 and it used the SAM3X8E as its foundation. To make it easier to program and integrate with other circuits, the boards employ female headers or single- or double-row pins. They have the option to link up with supplementary modules called shields. An I²C serial bus allows for the independent addressing of several, and even stacked, shields. Most boards come with a ceramic resonator or crystal oscillator that operates at 16 MHz and a 5 V linear regulator.

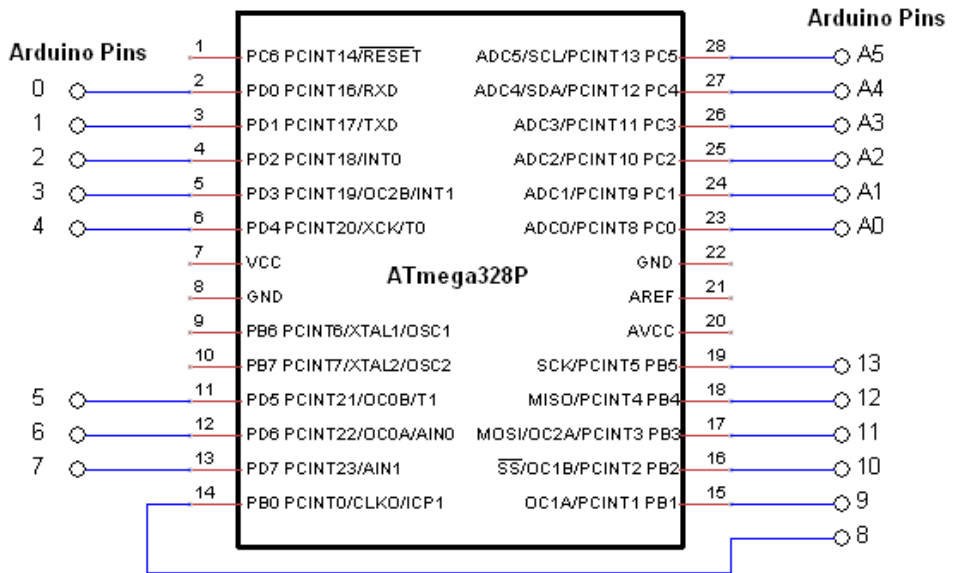

Figure 8: Arduino Uno Pin Description

Arduino microcontrollers are pre-stacked with a boot loader that works with the transferring of projects to their on-chip streak memory. As a default, the Arduino UNO utilizes the Opti boot bootloader. Boards may be programmed by connecting them to an external computer using a serial connection. To transform signals from RS-232 logic levels to TTL levels, a level shifter circuit is included into certain serial Arduino boards. The FTDI FT232 and other USB-to-serial converter chips allow modern Arduino boards to be programmed using the Universal Serial Bus (USB). Some boards may include an AVR chip with USB-to-serial software instead of an FTDI chip; this device may be flashed with fresh settings using its own ICSP header. This is common on later-model Uno boards. Bluetooth, a separable USB-to-chronic converter board, or both are utilized by a few variations, for example, the unapproved Boarduino and the little Arduino Small. While managing customary microcontroller devices rather than the Arduino IDE, standard AVR in-framework programming (ISP) is utilized.

There is a plethora of boards that are either directly or indirectly related to Arduino. Some of them are fully compatible with Arduino and may be used in place of it. To make building buggies and tiny robots easier, several people improve upon the original Arduino by adding output drivers; these boards are often used in educational settings. Others are

functionally similar but have a different shape; some of these variants are compatible with shields while others are not. There are versions that employ processors that aren't compatible with each other.

8 Operation of proposed surveillance system

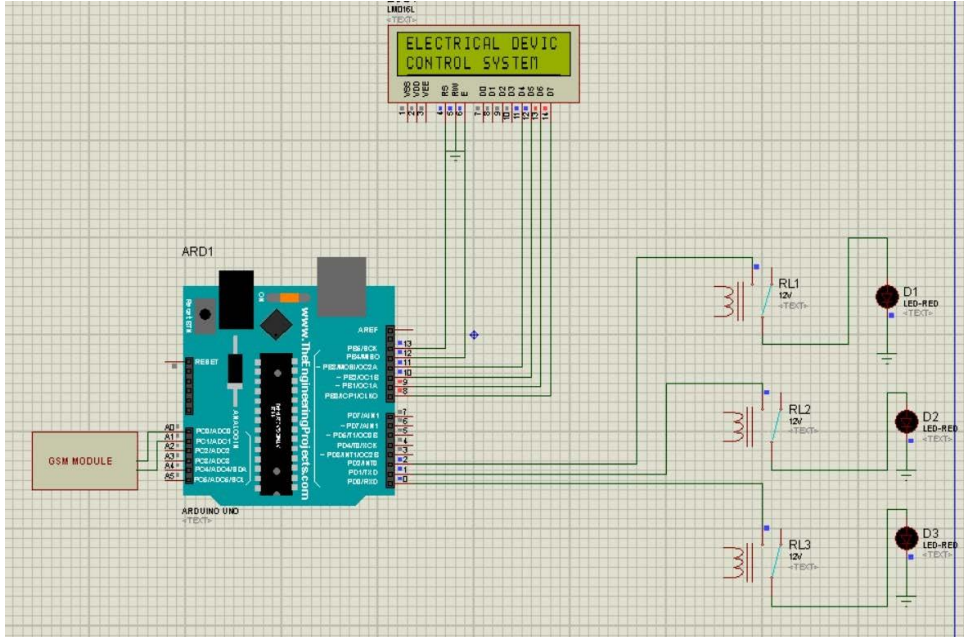

Figure 9 Connection diagram of surveillance system

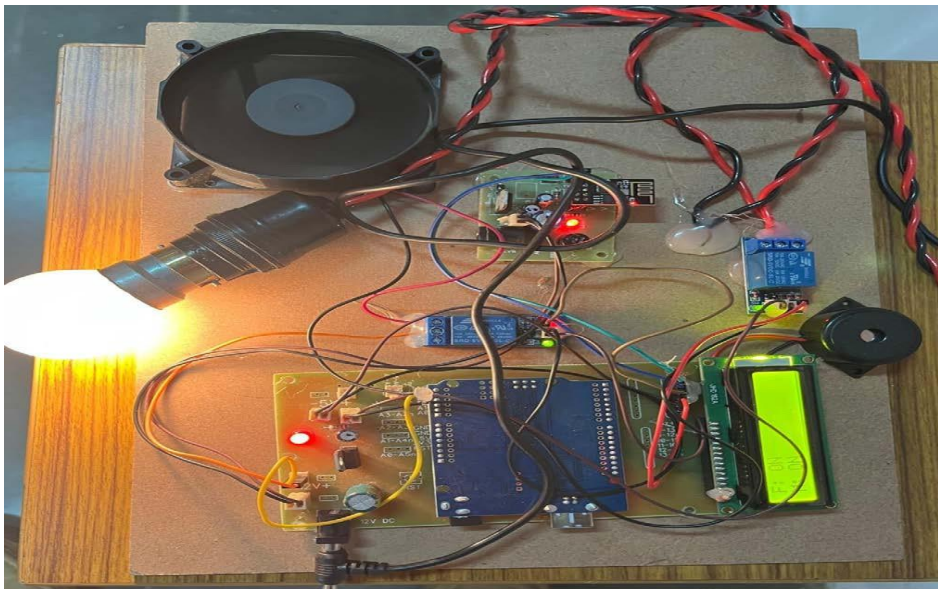

Figure 10 Hardware setup Control of Fan and Lamp Loads

Using WIFI, the electrical load management system connection diagram is shown in figure 9. The energy meter comes after the device's connection. A current sensor measures the total load current and sends the microcontroller a voltage signal that corresponds to it. To find the current, the microcontroller will transform the analogue reading into a digital one. After that, it checks the current reading against the default value. Do nothing when the current reading is below the threshold you've defined. The load will lose power as soon as the current reading goes beyond the set limit. Following a drop in load below the threshold, the user must re-engage the relay.

All the power consumption sites should have a device installed so that we can monitor the power consumption of individual loads at any given moment. Every customer has a certain amount of electricity that they are not allowed to exceed during the power outage. This way, we can meet the needs of all our customers. There is a power deficit, which determines the power limit. Using IoT technology, the device may be informed of the limit's value by SMS. In response to the current limit value, the controller will update the initial limiting value to reflect the current limit. In addition, we are also offering customers the ability to remotely turn their electrical loads on and off using text message. Separate passwords for the customer and the energy supplier guarantee the system's security by preventing the customer from setting the power limit value. At each given consumer point, the power supplier or distribution center may activate or deactivate loads, as well as establish current limit values.

The hardware experiment setup with light and fan control was shown in figure 9. A relay coil, Arduino uno board and power supply, metering equipment, Wi-Fi module with IoT With facility and LCD display were connected as per connection diagram. The experiment was conducted to control and operate the bulb and fan in various modes, and it was showing satisfactory results. The fan and light were operation on the control of proposed surveillance system which is shown in figure 10.

9 Conclusion

This article proposes a simple and quick process for surveillance system with the help of IoT with Arduino. Additionally, we have mitigated the drawbacks of the existing method using the proposed method. It is possible to set up direct, user-friendly interfaces between distributors and consumers without any third-party influence. Along with this, the system's accuracy improves when the number of mistakes decreases. In light of the above, it is safe to say that a user-friendly, cost-effective, and highly accurate system analysis is within reach and the proposed system provides all the above said features.

References

1. Sivanagaraju, S. and Sreenivasan, G. "Load frequency Control - II". Power System Operation and Control. Chennai, India
2. Criteria for economically efficient electricity wholesale markets - Criteria for economically efficient wholesale markets.
3. Independent Energy collapses with customers still owing £119m in bills - The Independent
4. "10 Jan 2008 Grid project lets consumer handle electricity use - United States". IBM.

- 2008-01-10. Retrieved 2012-02-02.
5. “Let there be light”. The Telegraph. 26 April 2009.
 6. Energy crisis from Wikipedia https://en.wikipedia.org/wiki/energy_crisis.
 7. <http://www.conserve-energy-future.com/causes-and-solutions-to-the-global-energy-crisis.php>
 8. WIFI Based Wireless Load-Shedding Management System for Non Emergency Condition by Patil P T1,Dattatraya raut2, Sagar Sutar3, Sandesh Narute4 from International Journal of Modern Trends in Engineering and Research
 9. WIFI Based Power Management by Kaukab Naz, Shahida Khatoon, and Ibraheem Kaukab Naz, Shahida Khatoon, and Ibraheem.